

Acta Orthopaedica

Acrylic bone cements

Influence of time and environment on physical properties

Markus Nottrott

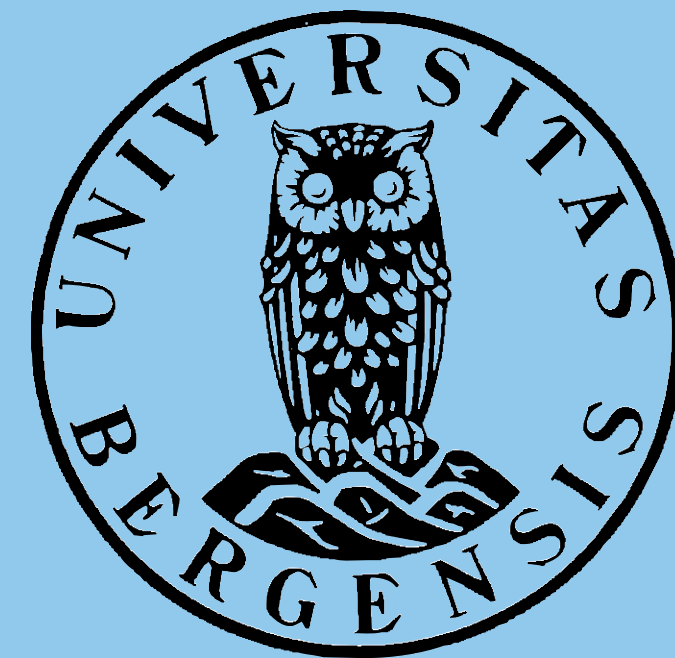

Department of Orthopedic Surgery
Haukeland University Hospital
Bergen, Norway
2010

Acrylic bone cements

Influence of time and environment on physical properties

Markus Nottrott



Thesis

Bergen, Norway 2010

ACTA ORTHOPAEDICA SUPPLEMENTUM NO. 341, VOL. 81, 2010

informa
healthcare

Contact address

Markus Nottrott, MD, PhD
Centre for Bone- and Soft tissue Tumours
Department of Orthopaedic Surgery
Haukeland University Hospital
NO-5021 Bergen
Norway
Tel.: +47 55972822
Mobil: +47 99532443
mkamn@kir.uib.no

Scientific environment

This study was initiated in 2002 and the work was carried out while working as a registrar, and later as a consultant at the Department of Orthopaedic Surgery, Haukeland University Hospital, Bergen, Norway. Supervision has been given by the staff from the Department of Clinical Dentistry Biomaterials, University of Bergen and Orthopaedic Biomaterials Department of Orthopaedic Surgery, Haukeland University Hospital, Bergen, Norway.

Financial support was given by Sophies Minde Foundation and the Institute for Surgical Sciences, University of Bergen, the health authorities of Western Norway (Helse Vest RHF, Helse Bergen HF, Innvest AS) and the Charnley Award 2008 from OrtoMedic.

Copyright © Informa Healthcare Ltd 2010. ISSN 1745–3674. Printed in Sweden – all rights reserved
DOI 10.3109/17453674.2010.487929

Printed in Sweden
Wallin & Dalholm
2010

We must not forget that when radium was discovered no one knew that it would prove useful in hospitals. The work was one of pure science. And this is a proof that scientific work must not be considered from the point of view of the direct usefulness of it. It must be done for itself, for the beauty of science, and then there is always the chance that a scientific discovery may become like the radium a benefit for humanity.

Marie Curie (1867–1934), *Lecture at Vassar College, May 14, 1921*

This thesis is based on the following papers, referred to in the text by their roman numerals:

- I. Nottrott M, Mølster A O, Gjerdet N R. Time dependent mechanical properties of bone cement. An in vitro study over one year. *J Biomed Mater Res B Appl Biomater* 2007; 83B (2): 416-21.
- II. Nottrott M, Mølster A O, Moldestad I O, Walsh W R, Gjerdet N R. Performance of bone cements – are current preclinical specifications adequate? *Acta Orthop* 2008; 79(6): 826-31.
- III. Nottrott M, Ruyter I E, Mølster A O, Moldestad I O, Gjerdet N R. Physical aging and the effect of water on mechanical properties of a poly(methyl methacrylate)-based bone cement. Submitted.
- IV. Nottrott M, Lie S A, Mølster A O, Furnes O, Schnell Husby O, Gjerdet N R. Dynamic creep and quasistatic properties of bone cements. Data from laboratory-made and retrieved specimens. Submitted.

Contents

ABBREVIATIONS AND DEFINITIONS, 2

ABSTRACT, 3

INTRODUCTION, 4

About hip arthroplasties, 4

History of bone cements, 5

Modern acrylic bone cement, 5

Composition and setting properties, 5

Cementing technique, 6

Product standards and preclinical testing, 6

AIMS OF THE STUDY, 7

SUMMARY OF PAPERS I-IV, 8

Paper I, 8

Paper II, 8

Paper III, 8

Paper IV, 9

MATERIALS AND METHODS, 10

Quality control, 10

Cements and preparation, 10

The cements for in vitro tests, 10

Preparation of in vitro specimens, 10

Collection and preparation of retrieved bone cement, 11

Quasistatic testing, 12

Time protocol, aging conditions, testing conditions and sample size for quasistatic in vitro testing, 12

Dynamic creep testing (Study IV), 13

Time protocol, aging conditions, testing conditions and sample size for dynamic creep testing, 13

Optical examination (Studies I and III), 13

Statistics, 13

SUMMARY OF RESULTS, 14

Quasistatic properties, 14

Dynamic creep properties, 14

Retrieval properties, 14

Optical findings, 15

GENERAL DISCUSSION, 16

Material tested, 16

Manufacturing variables, 16

Operator variables, 17

Test procedures, 17

Retrievals (Study IV), 18

Storage medium and water uptake, 18

Optical findings, 18

Quasistatic properties, 18

Creep properties, 19

CONCLUSIONS, 21

FUTURE RESEARCH, 22

ACKNOWLEDGEMENTS, 23

REFERENCES, 24

Abbreviations and definitions

Aging	Process that occurs in a polymeric material during a specified period of time, and that usually results in changes in physical and/or chemical structure and the properties of the material.	ISO	International Organization for Standardization.
ASTM	American Society of Testing and Materials.	Max. Strain	Maximum strain (in %).
BaSO₄	Barium sulphate (radiopacifier).	MMA	Methyl methacrylate.
BPO	Benzoyl peroxide.	PMMA	Poly(methyl methacrylate).
Creep	Time-dependent increase in strain in a material under constant or cyclic stress.	Quasistatic Strength	A static test but with adaptation to strain. In this work, used for the ultimate compressive strength.
DMPT	N,N-dimethyl-p-toluidine.	T_g	Glass transition temperature (in °C)
E	Elastic modulus (in GPa), Young's modulus.	THA	Total hip arthroplasty
EtO	Ethylene oxide.	UCS	Ultimate compressive strength (in MPa)
		ZrO₂	Zirconium dioxide (radioopacifier)

Abstract

Acrylic bone cements are in extensive use in joint replacement surgery. They are weight bearing and load transferring in the bone-cement-prosthesis complex and therefore, *inter alia*, their mechanical properties are deemed to be crucial for the overall outcome. In spite of adequate preclinical test results according to the current specifications (ISO, ASTM), cements with inferior clinical results have appeared on the market. The aim of this study was to investigate whether it is possible to predict the long term clinical performance of acrylic bone cement on the basis of mechanical *in vitro* testing.

We performed *in vitro* quasistatic testing of cement after aging in different media and at different temperatures for up to 5 years. Dynamic creep testing and testing of retrieved cement were also performed.

Testing under dry conditions, as required in current standards, always gave higher values for mechanical properties than did storage and testing under more physiological conditions. We could demonstrate a continuous increase in mechanical properties when testing in air, while testing in water resulted in a slight decrease in mechanical properties after 1 week and

then levelled out. Palacos bone cement showed a higher creep than CMW3G and the retrieved Boneloc specimens showed a higher creep than retrieved Palacos.

The strength of a bone cement develops more slowly than the apparent high initial setting rate indicates and there are changes in mechanical properties over a period of five years. The effect of water absorption is important for the physical properties but the mechanical changes caused by physical aging are still present after immersion in water. The established standards are in need of more clinically relevant test methods and their associated requirements need better definition. We recommend that testing of bone cements should be performed after extended aging under simulated physiological conditions.

Simple quasistatic and dynamic creep tests seem unable to predict clinical performance of acrylic bone cements when the products under test are chemically very similar. However, such testing might be clinically relevant if the cements exhibit substantial differences.

Introduction

As the global population ages, the incidence of osteoarthritis grows and the need for arthroplasty devices increases. Arthroplasties replace non-functional joints with artificial components. The most common type is the total hip arthroplasty (THA), followed by knee, shoulder, elbow and ankle arthroplasties.

Hospital costs for each primary THA are about \$11,000 (Iorio et al. 1999, Malchau et al. 2005, Yates et al. 2006, Healy and Iorio 2007). Thus, arthroplasties will pose an economic challenge for the health services. Due to the increased morbidity and the high costs of revision procedures, it is mandatory to use high-quality implant components. In this manner, revision procedures can be limited, to the advantage of the patient and to keep costs as low as possible.

To ensure the best arthroplasty outcome, procedures and all materials must be standardized and controlled (Ramsey et al. 1998). The present study highlights the role and properties of bone cement, one element in an arthroplasty.

About hip arthroplasties

In the 1890s, the German surgeon Gluck reported an attempt to replace the hip joint with ivory components using a cement made of plaster of Paris, but with unknown results (Gluck 1890, Gluck 1891). In the early 20th century, an attempt was made to place a material between acetabulum and the femoral head (interpositional membrane hip surgery), in order to restore mobility to painful hip joints (Smith-Petersen 1978, Hallab et al. 2004). Initially bladder or fascia was used, then a glass material and later a cobalt-chromium alloy (Venable et al. 1937, 1952). None of these methods were successful.

In the 1950s, a short stemmed femoral head replacement prosthesis made from an acrylic material (Judet and Judet 1950) was introduced. The initial results were good but there were implant fractures and excessive wear debris. Later in the 1950s, long-stem prostheses were introduced. These prostheses were metallic monoblock long-stem hemiarthroplasties that performed well provided that the acetabulum was not damaged. The need for acetabular repair led to the development of the metal-on-metal THA (Jacobsson et al. 1996, Brown et al. 2002). Initially, the prostheses suffered from the same problems as earlier prostheses: high frictional forces leading to liberation of debris that promoted early loosening.

Charnley recognised the problem (Charnley 1960) and developed a low friction arthroplasty in the 1960s, using a small femoral head, high-density polyethylene for the acetabulum and bone cement consisting of a cold curing acrylic material (bone cement) as fixation for the prosthesis (Charnley

1961). Further improvements of this type of prosthesis led to the most popular type of THA currently in use (Figure 1).

Today, approximately 7600 THAs are performed in Norway each year (Furnes et al. 2008), 14000 in Sweden (Kärrholm et al. 2007), 150000 in the US, and between 350000 and 1 million worldwide (Malchau et al. 1993, Metz and Freiberg 1998). Knee arthroplasties account for about half the number of THAs and additionally a large number of other arthroplasties, e.g. in the shoulder or in the ankle, are performed, showing the extensive use of different types of arthroplasties worldwide.

Taking THAs as example, fixation methods are cemented, cementless or hybrid. Hybrid means that either the femoral stem or the acetabular component is cementless while the other component is cemented. Cemented THAs were considered the “gold standard” for many years all over the world, but in recent years there has been a trend towards cementless hip arthroplasties, especially in the US and also in younger patients in Scandinavia (Kärrholm et al. 2007, Furnes et al. 2008). In Scandinavia, in about 90% of all THAs cement is used to fix one or both parts of the arthroplasty. However, in the USA all components are cemented in only 2% of cases and in 57%, hybrid implants (mainly with a cemented stem) are used (Johnston 2005).

An estimation based on the above mentioned data indicates that at least 2000 kg of bone cement is used in Norway alone per year.

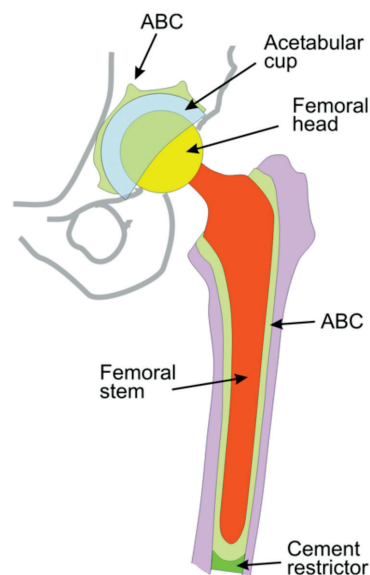

Figure 1. Schematic drawing of a cemented femoral component of a hip arthroplasty. ABC: Antibiotic loaded bone cement.

mum temperature is reached. (Kühn 2005, Kuehn et al. 2005a)

Bone cements are traditionally classified as low-, medium- or high viscosity cements (Kühn 2000). These are differentiated by some properties during the different phases of cement setting. The classification of bone cement viscosity is in transition and could be affected by market terminology (Watkins 2003). Generally, a low viscosity cement has a long-lasting waiting phase, up to three minutes, then viscosity increases quickly in the working phase, whereas a high viscosity cement has a short waiting phase and a long working phase during which the cement changes slowly before setting (Kühn 2000).

Cementing technique

Mixing procedures have a significant influence on bone cement quality (Lidgren et al. 1987, Linden 1989, Norman et al. 1995, Lewis et al. 1997, Lewis 1999b, Dunne and Orr 2001, Dunne et al. 2005). Traditionally, bone cement was prepared by open bowl mixing whereby liquid and powder were mixed with a spatula in a bowl. The result could have high porosity because of air entrapment or heterogeneous mixing of the components and exposure of the operation theatre staff to high levels of MMA vapour could occur. In this so-called first generation cementing technique, the cement dough was antegrade poured into the medullary canal. In the second generation cementing technique, several improvements of mixing technique, bone preparation and insertion of the cement were proposed (Mulroy et al. 1995). A modified mixing bowl allowed vacuum mixing or centrifugation of the cement (Davies et al. 1989a). An intramedullary plug was used and the femoral medullary canal was prepared with rasping, curettage, irrigation and drying. The cement was then applied by retrograde filling of the canal with a cement gun. The third generation cementing technique refined these improvements and is seen today as the modern cementing technique. The cement is chilled and its preparation is performed in a cement gun that allows mixing and collection under vacuum (Lidgren

et al. 1987) and pressurisation of the cement dough while filling the medullary canal (Oates et al. 1995). Vacuum mixing has been shown to reduce the cement's porosity (Alkire et al. 1987, Wang et al. 1996) and increase its mechanical strength (Lidgren et al. 1984, Jasty et al. 1990).

Product standards and preclinical testing

Standards are documents that, among other aspects, ensure the conformity, quality, safety and reliability of products (International Organization for Standardization 2008).

In 1976 the ASTM (American Society for Testing and Materials) standard F451-76 (Standard Specifications for Acrylic Bone Cements) was the first standard for bone cement. That was the basis for the ISO standard 5833/1 that was published three years later (Kühn 2000).

Today, the specifications for bone cements are ISO 5833:2002 and ASTM F451-99a (Demian and McDermott 1998, American Society for Testing and Materials 1999, ISO 2002). The standards for acrylic bone cements contain requirements and test methods, related to compressive strength, after 24 hours. Compressive strength should be at least 70 MPa. Also bending modulus (≥ 1800 MPa) and bending strength (≥ 50 MPa) must be determined. Additionally, the standards define doughing time, setting time, maximum curing temperature, packaging and labelling of the cement.

Preclinical testing is intended to predict the clinical behaviour of bone cements. Fulfilment of a standard's requirements may not be sufficient to ensure clinical success. The past has shown that bone cements that fulfilled requirements in contemporary standards performed poorly clinically (Havelin et al. 1995, Herberts and Malchau 2000). A well known example is a methylmethacrylate/n-decylmethacrylate/isobornylmethacrylate (MMA/DMA/IBMA) bone cement (Boneloc) which was introduced on the market in the early 1990s. It performed poorly in spite of preclinical test results that were deemed adequate (Thanner et al. 1995, Nilsen and Wiig 1996, Furnes et al. 1997, Carlsson 1998).

Aims of the study

The overall aim of this study was to investigate the possibility of predicting the long term clinical performance of acrylic bone cements based on preclinical *in vitro* physical testing.

The specific aims were:

1. To address changes in mechanical properties and microstructure of one bone cement aged *in vitro* under simulated physiological conditions for up to 1 year.
2. To discriminate between test results under “physiological” conditions compared with “standard” conditions.
3. To study the effects of physical aging and water uptake on the mechanical properties of a PMMA-based bone cement.
4. To assess whether a dynamic creep testing protocol as well as quasistatic testing can reveal properties relevant to the long term clinical performance of different cement brands.

Summary of Papers I–IV

Paper I – Time dependent mechanical properties of bone cement. An *in vitro* study over one year

Background: Changes in mechanical properties of bone cements over time are of clinical importance, but not well documented. Specifications for testing do not address the time factor.

Methods: This study recorded changes in compressive properties and microstructure of one bone cement stored under simulated physiological conditions (water at 37°C) from 20 minutes up to 1 year and in dry air at 37°C for comparison.

Results: Compressive strength increased within the first week ($p < 0.001$), decreased at 1 month ($p < 0.001$), and remained at that level at 1 year. Elastic modulus showed a similar development. Maximum strain values, indicating plastic deformability, increased continuously over 1 year. Microscopy revealed microcracks between the pre-polymer beads and the matrix in specimens tested after 20 minutes, whereas there were fewer cracks in 1 year specimens.

Interpretation: Increase in strength during the first week is due to polymerisation and formation of interpenetrating molecular networks. The subsequent decrease could be due to the plasticizing effect of water uptake, as supported by higher values for dry specimens. It can be speculated that microcracks which could be initiated while reducing an arthroplasty at 15 min, acting as initiators for fatigue fractures in the cement mantle, contribute to cement failure. It is recommended that testing of bone cements should be performed after extended aging at simulated physiological conditions, for the present cement at least 5 weeks. Results obtained at less than one week could be influenced by ongoing polymerisation, as well as microcracks and lower coherence between the prepolymer beads and the matrix.

Paper II – Performance of bone cements: are current preclinical specifications adequate?

Background: Current specifications (standards) for preclinical testing of bone cements (ISO 5833: 2002, ASTM F451-99a) require simple mechanical testing after aging for 24 hours under dry conditions at 23°C. Some bone cements have fulfilled the requirements in the specifications, and yet had inferior clinical results. Clinically, bone cements are subjected to complex loading patterns in a moist or wet environment at 37°C. Thus the validity as well as the robustness of current standard testing protocols can be questioned.

Methods: The influence of temperature and storage medium on the properties of bone cement was examined. We compared the results of storing and testing under standard conditions of 23°C in dry air, with the results obtained at 37°C in water or plasma.

Results: The dry specimens showed an increase in strength and elastic modulus with time, while the values for wet specimens decreased. There was no difference between specimens stored in water or in plasma. Ultimate compressive strength of dry specimens after 24h was 1.16 times higher than that of those stored wet, increasing to 1.34 times after 1 month, and 1.46 times after 6 months ($p < 0.001$ for all comparisons).

Interpretation: Testing under dry conditions as required in current standards always gave higher values for mechanical properties than did storage and testing under more physiological conditions. The sensitivity of test values to different environments implies that testing conditions for bone cements should be scrutinized in order to develop more relevant testing protocols that more closely replicate the *in vivo* environment.

Paper III – Physical aging and the effect of water on mechanical properties of a poly(methyl methacrylate)-based bone cement

Background: The aim of this study was to describe the effects of physical aging and the effect of water on the mechanical properties of a PMMA-based bone cement. Such cements are auto-curing PMMA powder/MMA monomer products that polymerise *in situ*.

Methods: After mixing and curing, the cement had been stored unloaded for 5 years in air at 23°C. Three groups of specimens were tested in compression at 23°C: One group was tested in the dry state (Group A1), another group was stored in water at 37°C for 3 weeks before testing (Group A2), and a third group that had been stored in water, was re-dried for 3 weeks at 23°C before testing (Group A3). A group of freshly made specimens, tested after 24 hours, 5 weeks, and 6 months (Groups B1–B3), was included for comparison.

Results: There was a continuous increase in ultimate compressive strength (UCS) and E-modulus (E) from 24 hours up to 5 years. Group A1 and A3 had similar values for both UCS and E ($p > 0.05$), while group A2 had statistically significantly lower values ($p < 0.001$).

Interpretation: The increase in mechanical properties during five years is interpreted as an effect of physical aging. The plasticizing effect of water decreased the mechanical properties to approximately the same level as the newly set material. Re-drying for another three weeks gave values similar to those of the 5-year old dry specimens. Thus it is demonstrated that the effect of water absorption is reversible. Moreover, it is suggested that the mechanical effects of physical aging remain after immersion in water.

Paper IV – Dynamic creep and quasistatic properties of bone cements: Data from laboratory-made and retrieved specimens

Background: Data from the Norwegian arthroplasty registry have revealed that femoral stems cemented with a low/medium viscous bone cement (CMW3G) had poorer clinical outcomes than those cemented with a high viscosity cement (Palacos). Data for specimens made from a cement with an unconventional composition (Boneloc) that had performed poorly and been taken off the market about 14 years earlier, were also included.

Methods: *In vitro* quasistatic compression as well as dynamic creep testing (50 MPa @ 1 Hz) was performed on both laboratory-made specimens and on specimens from retrieved cement obtained during revision surgery.

Results: Generally, the low/medium viscosity cement had higher values for compressive strength and E-modulus than the high viscosity product, whereas the creep was lower. The

historic cement had distinctly lower strength and modulus of elasticity than a high viscosity cement. Values for specimens from the retrieved historic cement were at least three times higher than those from the conventional cements, and they failed before reaching 20,000 cycles of dynamic testing. The conventional cements withstood more than 500,000 cycles.

Interpretation: The present results did not reveal major differences in quasistatic properties or creep behaviour of the conventional cements, demonstrating the similarity of these products. The historic Boneloc cement, on the other hand, represented a product with distinctly different properties, particularly with regard to creep behaviour, from the traditional PMMA-based products. The difference in long-term clinical performance between the two modern cements is not directly reflected by the present short-term laboratory tests. The higher creep of the cement with reported good clinical performance (Palacos) may indicate that some creep could be advantageous. Creep as high as that observed in the Boneloc cement appears to be detrimental with respect to clinical outcome.

Materials and methods

Quality control

All equipment used in the studies was calibrated or controlled for accuracy before use and the test results were reproducible, as we could show by repeating some tests at the same time points and under identical conditions. Data files were proof-read once in all studies by different co-workers.

The test methods used in the different studies were well established and are modifications to existing standard testing procedures.

Storing conditions were the same for all cement packages. Cement mixing and preparation of specimens was undertaken by the same investigators in all studies.

Cements and preparation

The cements for *in vitro* tests

The three bone cements used in this study were Palacos R-40 cum Gentamicin (Schering Plough), Boneloc (Polymers Reconstructive A/S) and CMW 3G (De Puy). Table 1 shows the chemical composition of these bone cements.

Preparation of *in vitro* specimens

The cements were precooled to 4°C prior to mixing and prepared according to the manufacturers' instructions at 23°C and 40-60% relative humidity. Cement preparation was performed in a sterile cartridge (Optivac S, ScandiMed Implant AB, Sjöbo, Sweden). The Optivac S system allowed mixing and collection under vacuum in a closed system (Dunne and Orr 2001) (Figure 4).

The components in the cartridge were mixed at vacuum levels below 0.15 bar for about 40 seconds, then the cartridge was transferred to a cement gun (ScandiMed Implant AB, Sjöbo, Sweden). At approximately dough time, usually after 3.5 minutes, the cement was injected into polytetrafluoroethylene moulds (NIOM, Haslum, Norway) to produce cylindrical 6x12 mm test specimens according to ISO 5833 (ISO 2002) (Figure 5).

The cement was allowed to cure for 15 minutes. The specimens (Figure 6) were removed from the moulds and wet-ground (DAP-V, Struers, Copenhagen, Denmark) to ensure that the end surfaces of the specimens were perpendicular to the long axis. Length, diameter and mass were recorded.

Table 1. Composition of the bone cements used in this work (information from the manufacturers)

Powder Sachet (Palacos and CMW3G) Boneloc in Vacuum Pack	Palacos R-40 cum Gentamicin (Schering-Plough) Lot no.: 1-NFBA-20/9430 40.8 g	CMW 3G (De Puy) Lot no.: Y138B40 40.0 g	Boneloc (Polymers Reconstructive A/S) Lot no.: 503171 55.6 g
Methylmethacrylate / methylacrylate copolymer	82.84%	83.8%	90.0%
Benzoyl peroxide	0.49%	1.9%	0.9%
Zirconium dioxide	14.71%	–	10.0%
Barium sulphate	–	10.0%	–
Chlorophyll	0.002%	–	–
FD & C Blue No. 2 Al. Lake	–	–	0.1%
Gentamicin	1.96%	4.2%	–
Liquid In glass cartridge (Palacos and CMW3G) Boneloc in Vacuum Pack	Palacos R-40 cum Gentamicin (Schering-Plough) Lot no.: 0-RDCA-67/3264 18.8 g	CMW 3G (De Puy) 17.9 g	Boneloc (Polymers Reconstructive A/S) Lot no.: 503171 24.4 g
Methylmethacrylate (MMA)	97.87%	97.50%	50.0%
Decyl methacrylate	–	–	30.0%
Isobornylmethacrylate	–	–	20.0%
N,N-dimethyl-p-toluidine	2.13%	2.5%	0.5%
Dihydroxypropyl-p-toluidine	–	–	0.9%
Chlorophyll	0.002%	–	–
Hydroquinone	60 ppm	25 ppm	–
Hydroquinone + Hydroquinone- monomethyl ether	–	–	100 ppm

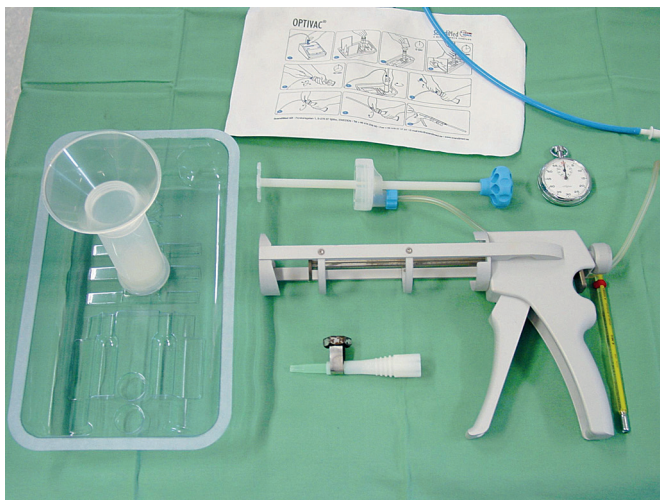

Figure 4. Vacuum mixing system with cartridge, nozzle, stopwatch, thermometer and cement gun.



Figure 5. Moulds according to ISO 5833 to produce cylindrical 6x12 mm test specimens.

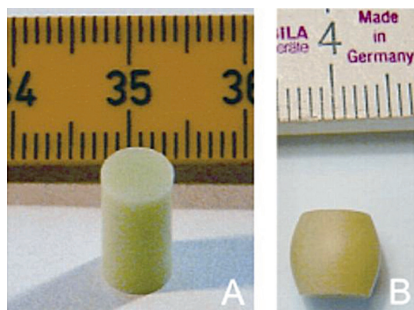

Figure 6. Test specimen before testing (A), barrel-shaped test specimen after testing (B).

All samples were stored unloaded. Test specimens were obtained from different mixing procedures and were randomly assigned to the testing groups. All test specimens were from the same lot (batch) of the respective cement type (Table 1). The coherent design of the experiments allowed use of data across different studies.

Table 2. Retrieved bone cement

Pat #	Type of bone cement	Years in use	Reason for revision
1	Palacos with Gentamicin	10.25	Aseptic loosening
4	Palacos with Gentamicin	11.17	Aseptic loosening
6	Palacos with Gentamicin	9	Aseptic loosening
7	Palacos with Gentamicin	8.88	Aseptic loosening
8	Palacos with Gentamicin	6.88	Aseptic loosening
10	Palacos	19.25	Aseptic loosening
14	Palacos with Gentamicin	9.83	Aseptic loosening
16	Palacos with Gentamicin	5.75	Aseptic loosening
B7	Boneloc	2.83	Aseptic loosening
B8	Boneloc	3	Aseptic loosening
B9	Boneloc	2.5	Aseptic loosening
B10	Boneloc	2.83	Aseptic loosening
B11	Boneloc	3.17	Aseptic loosening
B15	Boneloc	3	Aseptic loosening
B16	Boneloc	3	Aseptic loosening
B27	Boneloc	4	Aseptic loosening

In Study II, the two values from testing in plasma were compared with values from the same respective time points in Study I. In Study III, the increase in values over up to 5 years was demonstrated by comparison with the values from Study II in air at 23°C for 24 hours, 1 month, and 6 months. In Study IV, the two values of CMW3G were compared with results from the corresponding time points of Study II.

Test specimens for creep testing were primarily prepared as described above but, after the cement had set, were milled to a size of 3x6 mm using the same method that was used for retrieved bone cement fragments; it was not technically possible to test bone cement specimens of the size 6x12 mm in the actuators.

Collection and preparation of retrieved bone cement

Bone cement was retrieved from patients who had undergone hip revision surgery for aseptic implant loosening. Surgery was performed in two different hospitals in the Bergen area by different orthopaedic surgeons. Permission to collect the cement and some patient data was given both by the local ethical committee (REK III nr. 025.02, 04.03.2002) and the Norwegian Social Science Data Service (Ref.: 200200235 GHA/RH, 06.03.2002, Project: 9026).

We obtained sufficient usable bone cement pieces from eight patients with Palacos but unfortunately no patient had received CMW3G cement. We also had access to test specimens of Boneloc cement, prepared in 1995 and recovered from eight patients. These bone cement fragments were prepared and tested under the same conditions as the retrieved Palacos specimens.

Retrieved bone cement was postoperatively stored in water at 37°C until specimen preparation was finished, then the specimens immediately underwent compression and creep tests in water at 37°C. The age of the retrieved bone cement ranged from 5.75 years to 19.25 years for Palacos cement and from 2.5 to 4 years for the Boneloc cement (Table 2).



Figure 7. Retrieved bone cement. In this special case the whole cement mantle was debonded from the bone and could be removed with the prosthesis, without fragmenting the cement.

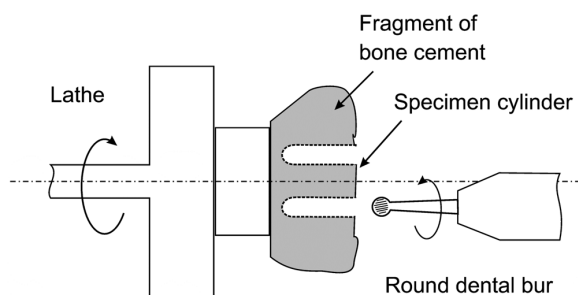

Figure 8. Schematic of preparing test specimens from the retrieved bone cement. The same method was used for preparing test specimens for dynamic creep testing.

Cylindrical specimens (3 mm diameter x 6 mm height) were prepared from the retrieved cement (Figure 7) by milling.

Specimen preparation was performed in a lathe, using a ball-shaped dental bur (Komet, ISO 500, HI 023) as the cutting tool. The bur was constantly flushed with water during the shaping process (Figure 8). The end surfaces of the specimens were wet-ground as described above.

Quasistatic testing

The cement specimens were mechanically tested in compression with a servo-hydraulic testing machine (Material Test System 810, Model No. 318.10, MTS Systems Corp., Minneapolis, USA) with a compression jig equipped with a strain transducer (NIOM, Haslum, Norway) located close to the specimen under testing (Figure 9).

The testing took place in 23°C air or in water maintained at 37 ± 0.5°C. After the specimen was placed in the test chamber, a constant cross-head speed of 24 mm/min (ISO 2002) was applied until the stress value fell to a minimum and the test specimen fractured (Figure 10). Deformation and load were sampled continuously. Ultimate compressive strength, UCS (in MPa), maximum strain (in %), and E-modulus, E (in GPa), were calculated from the resulting stress-strain curve (Figure 10).

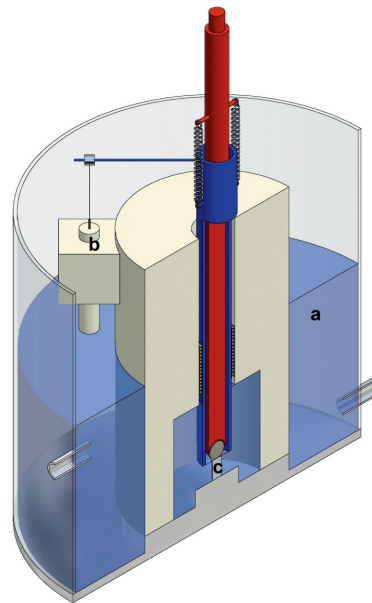

Figure 9. Schematic drawing of the experimental configuration, a) water 37°C, b) strain transducer, c) test specimen.

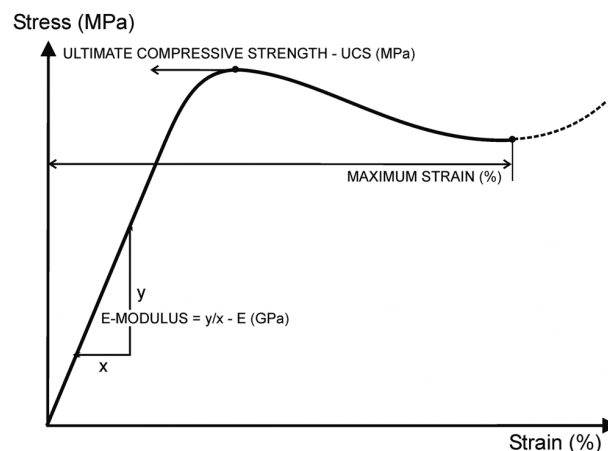

Figure 10. How the mechanical variables were deduced from the stress/strain curve.

Time protocol, aging conditions, testing conditions and sample size for quasistatic in vitro testing

The start of mixing of powder and liquid was always taken as the zero point in time.

After preparation, the specimens were aged in: Air at 37°C (Study I), air at 23°C (Study II, III), water at 37°C (Study I - IV), and plasma at 37°C (Study II). Testing of the respective samples was performed in an identical environment as for aging, except for the plasma group that was tested in water at 37°C for reasons of hygiene.

Mechanical tests were performed after 20 minutes (min), 1 hour (h), 6 h, 24 h, 1 week, 3 months, and 12 months (Study I). In Study II, tests were performed after 24h, 1 month, and 6

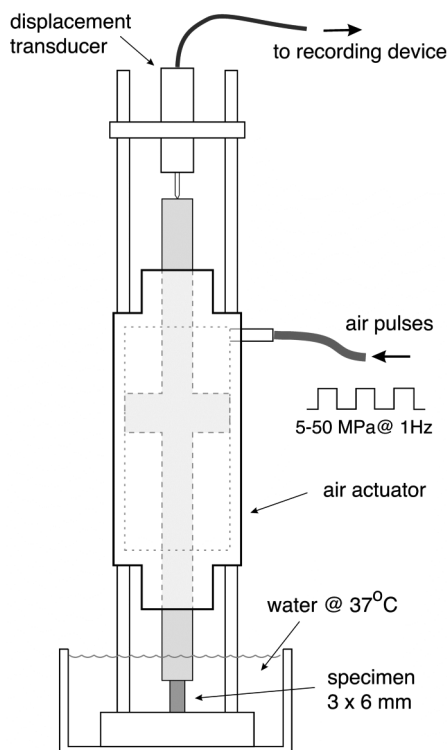

Figure 11. Schematic drawing of a pneumatic actuator for dynamic creep testing.

months. In Study III, tests were performed after five years, five years + 3 weeks and five years + 6 weeks. In Study IV, tests were performed after 24 h, 48 h and 6 months. An adequate sample size was tested at each time-point.

Dynamic creep testing (Study IV)

Dynamic creep testing was performed using pneumatic actuators (FESTO AG & Co, Esslingen, Germany) placed in a water bath at 37°C to apply dynamic forces (Figure 11). A displacement transducer (Hottinger Baldwin Messtechnik GmbH, Darmstadt, Germany) was used to record deformation continuously. The dynamic forces were actuated by a pneumatic system of valves, pressure regulators and a counter (all FESTO AG & Co, Esslingen, Germany).

A force of 50 MPa was applied with a frequency of 1 Hz up to 600,000 cycles. The load of the pneumatic actuators was controlled (Force transducer, Type: C9B, HBM, Darmstadt, Germany) intermittently to ensure that there had been no drift in load.

Time protocol, aging conditions, testing conditions and sample size for dynamic creep testing

In vitro specimens for dynamic creep testing were stored for 6 months in water at 37°C and then tested in water at 37°C for at least 600,000 cycles or until failure of the specimen occurred.

Twelve *in vitro* specimens of CMW3G and 9 *in vitro* specimens of Palacos cum Gentamicin were tested.

Optical examination (Studies I and III)

Untested and mechanically tested specimens were embedded parallel with the long axis in a cold-setting epoxy resin (EpoFix™, Struers, Copenhagen, Denmark) about one year after preparation. After curing, the specimens were wet-ground (TergaForce -1, Struers, Copenhagen, Denmark) with different grinding discs using a force of 10 N and finally polished with polishing cloths and an alumina water-based polishing liquid (DiaPro Dac, MD Mol and MD Nap, Struers, Copenhagen, Denmark). The polished blocks were placed in 25% tetrahydrofurane (THF) for 10 minutes to etch the surface (Puska et al. 2004). The middle area of the specimens, which corresponded to the most deformed part, was examined in an incident light microscope (Leica DMIRM, Leica Microscopy Systems, Wetzlar GmbH, Germany).

Statistics

The statistical analysis was performed using MINITAB Release 14.12.0 (Minitab Inc., State College, PA, USA) and SPSS version 13.0 and 15.0 for MS-windows (SPSS Inc. Chicago USA).

In Studies I and III, we used an ANOVA for testing differences between mean values for the different time-points. To determine for which time-points the means differed, post hoc analyses were done, adjusting for multiple comparisons. All p-values less than 5% were considered statistically significant.

In Study II, a generalized linear model (GLM) was used to model an ANOVA to determine differences between the different groups as well as for the different time-points in the specific group. The group differences were tested at each time point in the GLM using a categorical variable defined with an interaction of time. All p-values less than 5% were considered statistically significant.

In Study IV, statistical differences in the simple compression tests between the different cement types were assessed using standard t-tests. The average creep value for each of the cement types was based on the predicted values from a mixed linear regression model. In this model, the test specimen was entered as a random coefficient while the natural log transformation of time (the number of cycles) was entered as a linear continuous variable. The covariance structure for the random coefficient was set as autoregressive (1st order, AR(1)). Furthermore, to distinguish between the different creep rates for the cement types, an interaction term between the log transformed age and the cement types was entered. Calculation of pointwise 95% confidence intervals was done using the estimated standard errors.

Summary of results

In the following, the results for Studies I–IV are cumulated. A more detailed description can be found in Papers I–IV of this thesis. Specimens of the individual cement types are all from batches with identical lot numbers and they were therefore comparable with each other even though produced at different time points.

Quasistatic properties

Palacos cum Gentamicin specimens tested in water displayed increased ultimate compressive strength (UCS) until a maximum was reached after 1 week. Thereafter, UCS decreased 5.5% during 3 months, then levelled off (Figure 12).

The results for UCS from specimens tested in air (at 23°C and 37°C) showed higher values for all testing time points compared with specimens tested in water, and there was a continuous increase in strength over time. However, there was no difference between testing at 23°C or 37°C in air (Figure 12).

CMW3G always had higher values for UCS than Palacos cum Gentamicin but showed a performance similar to that of Palacos cum Gentamicin, with increasing values in air and decreasing values in water (Study IV).

Laboratory specimens of the historic Boneloc cement, that had been tested about 14 years earlier, revealed that the UCS and E-modulus were significantly lower than those of the Palacos cement ($p=0.005$ for UCS; $p=0.028$ for E).

The elastic modulus for Palacos cum Gentamicin at 20 min was 78% of maximum, which was reached at 24 hours and was followed by a decrease of 7.4% at 1 year (Figure 13).

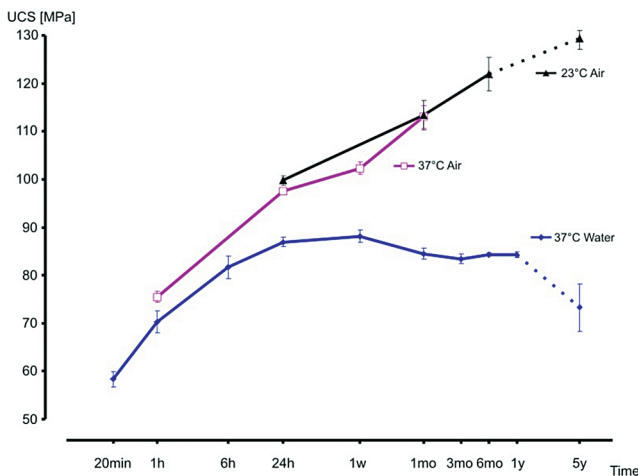

Figure 12. Mean ultimate compressive strength (UCS) with 95% confidence intervals (CI) for Palacos cum Gentamicin, logarithmic time scale.

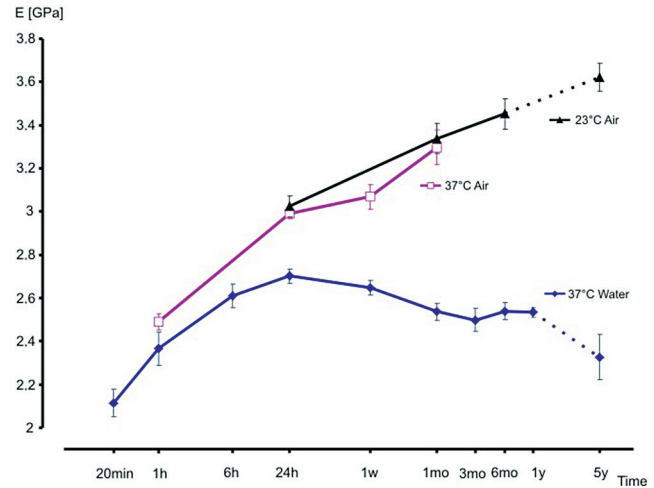

Figure 13. Mean E-modulus with 95% CI for Palacos cum Gentamicin, logarithmic time scale.

The E-modulus for CMW3G, tested in water at 37°C, was higher compared with Palacos cum Gentamicin except for the 6 months value. E-modulus increased between 24 hours and 6 months for both cements when tested in 23°C air but decreased when tested in water at 37°C.

Storage of Palacos cum Gentamicin specimens in plasma or in water gave approximately identical values for UCS and E-modulus (Study II).

Dynamic creep properties

Palacos cum Gentamicin showed a statistically significant ($p<0.001$) higher creep value than CMW3G when testing the *in vitro* specimens in 37°C water (Figure 14). Both cements could be tested 600,000 cycles without fracturing.

Retrieval properties

Boneloc showed a statistically significant ($p<0.001$) higher creep value than Palacos when testing retrieved specimens in dynamic creep at 37°C in water (Figure 15). Most of the Boneloc specimens were destroyed after 20,000 cycles of testing while Palacos specimens survived the whole testing line of 600,000 cycles.

The UCS of the retrieved Palacos specimens was not significantly different ($p=0.81$) from the *in vitro* 6 month values in 37°C water while E-modulus showed statistically significantly ($p=0.008$) lower values.

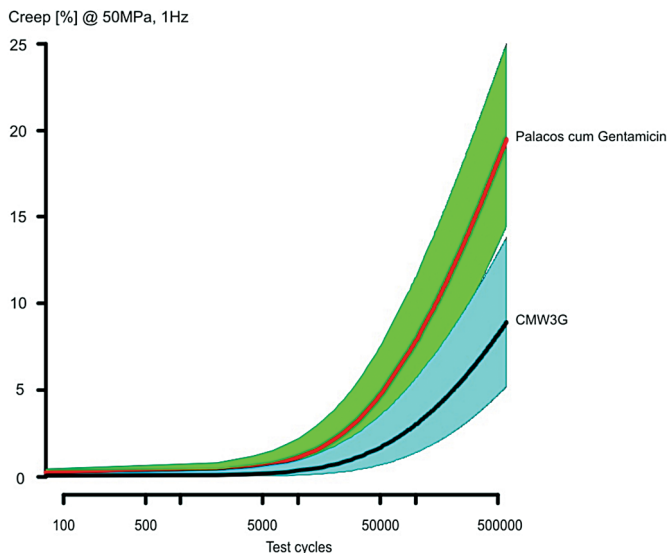

Figure 14. Estimate of dynamic creep for CMW3G and Palacos with 95% CI.

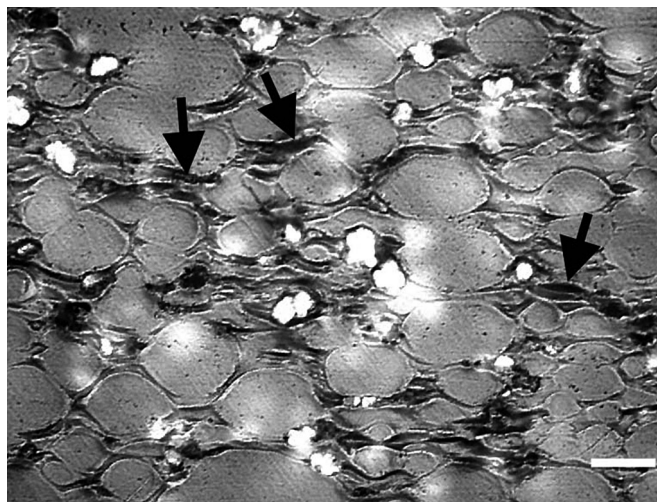

Figure 16. Optical micrograph of etched surfaces of bone cement specimen which had been mechanically tested at 20 minutes after preparation. The application of force was in the vertical direction. Arrows: Microcracks (gaps) between pre-polymer beads and polymer matrix. Horizontal bar: 50 μ m

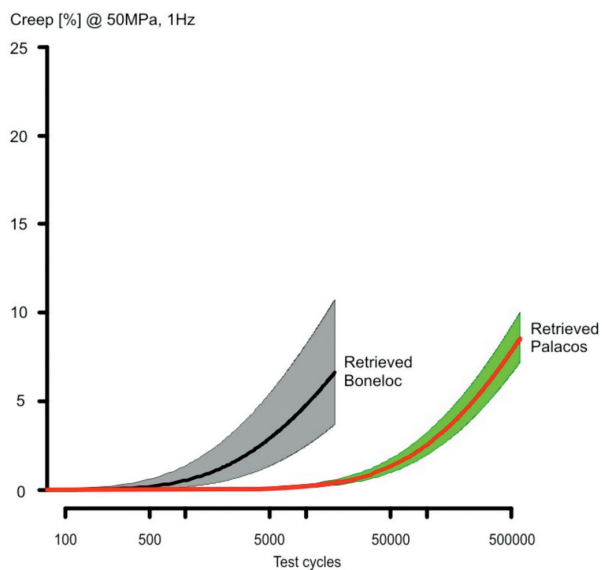

Figure 15. Estimate of dynamic creep with 95% CI for retrieved Boneloc and Palacos

Optical findings

Examination of the central area of the tested specimens, which had been subjected to high strains, showed that the pre-polymer beads had been distinctively deformed as a result of the compression. Specimens tested 20 minutes after mixing were characterised by separation of the pre-polymer (PMMA) beads from the newly formed polymer matrix, forming microcracks at the interfaces (Figure 16). Dispersed particles of the radioopacifier were clearly visible (Figure 16).

General discussion

New devices, components, and techniques are chosen because they may offer improvements. Preclinical, *in vitro* investigations of cemented arthroplasties are essential to quantify such improvements and to assess prognostic issues for the operation. In this way, material safety will be improved and users' and patients' confidence in the new product increases. Nevertheless, this *in vitro* testing has proven difficult because of the complexity of the bone-cement-prosthesis system *in vivo*. Factors that influence the validity of these investigations will be discussed in the following pages.

A randomised clinical trial would provide an opportunity to assess the quality of materials. The drawback is that such a trial would involve a very long follow-up and a large number of participants would be required to detect differences. By the time the results are available, the materials or techniques in question could already be outdated (Grossman and Mackenzie 2005) and new ones might have appeared on the market. This is also a problem for registries of implant survival. While they provide good information about available materials that were used previously, and, due to large numbers and long follow-up, they detect even small differences, they cannot predict the potential success of new materials. On the other hand, by continuous registration, they can identify a trend towards poorer outcomes at an early stage. This happened in the case of Boneloc cement after only three years (Nilsen and Wiig 1996, Furnes et al. 1997). In the case of CMW3G, it required 6 – 10 years to reveal the material's shortcomings (Havelin et al. 1995, Espehaug et al. 2002). The ideal, of course, would be to prevent the appearance of such products on the market.

Materials tested

The validity of the results reported here is limited to the materials tested, but materials with similar composition and fabrication are probably quite comparable with those in the present studies.

In all studies (I–IV), one brand of bone cement (Palacos R cum Gentamicin, Schering Plough) with well documented good long-term clinical results was used (Havelin et al. 1995), and this material is considered representative for other cements which have similar composition.

In Study IV, we tested in addition two other cement brands (CMW3G and Boneloc) that had shown inferior results in registries of implant survival, compared with Palacos cement (Havelin et al. 1995, Riegels-Nielsen et al. 1995, Nilsen and Wiig 1996, Furnes et al. 1997, Espehaug et al. 2002). These two cements were chosen for comparison because of their

proven poorer clinical results and our desire to quantify their clinical differences in short term *in vitro* testing.

We tested three different types of bone cement with different viscosity. Palacos R cum Gentamicin is classified as high viscosity bone cement while Boneloc is classified as low viscosity cement, and CMW3G as medium viscosity cement. CMW3G was originally marked and classified as a low viscosity cement (Havelin et al. 1995, Kühn 2000, Espehaug et al. 2002) but is currently classified and marked as medium viscosity cement (Watkins 2003, Race et al. 2005).

Manufacturing variables

The results of our studies are influenced by manufacturing variables like sterilization method, chemical composition and additives. These variables are constant factors for the commercial product and are independent of the user.

Increasing molecular weight increases the strength of a polymer (Ruyter and Svendsen 1980, Lewis 2000). Sterilizing the cement powder by γ - or β -irradiation degrades the fracture toughness of the set material by lowering the molecular weight, unlike ethylene oxide (EtO) gas sterilization (Harper et al. 1997, Lewis and Mladiš 1998, Lewis 1999a, Kuehn et al. 2005a). The cements tested in this study were sterilized by different methods and have accordingly different molecular weights. The higher molecular weight of Palacos bone cement compared with CMW3G (Kühn 2000) could probably influence the mechanical properties of the cements but the clinical relevance of such changes due to sterilisation has to be further investigated (Ries et al. 2006).

The most commonly used radioopacifiers in commercial bone cements are BaSO_4 and ZrO_2 . In case of the cements studied here, Palacos R cum Gentamicin and Boneloc contain ZrO_2 and CMW3G contains BaSO_4 . BaSO_4 has been claimed to be a stress raiser, a crack initiator and a pore creator in the interbead matrix (Lewis 2000, Kurtz et al. 2005) but biological factors, influencing cell differentiation around the cement bone interface, with possible effects on aseptic loosening, have also been reported (Jasty et al. 1992, Jasty and Smith 1992, Shardlow et al. 2003, Breusch and Kuhn 2003, Lewis et al. 2005b, Bader et al. 2005). These mechanisms were not addressed in this study but could influence the clinical performance of these bone cements.

Bone cement with premixed antibiotic powder is widely used in Scandinavia (Dunbar 2009). The Norwegian Arthroplasty Register reports the use of 96% antibiotic laced bone cements in primary THAs (Furnes et al. 2008), in contrast to the USA (Heck et al. 1995). The mechanical properties of acrylic bone cement are not significantly affected by adding an antibiotic powder (Saha and Pal 1984, Davies et al. 1989b,

Lewis et al. 2005a, Brock et al. 2009). In the present work, both Palacos and CMW3 contained Gentamicin, added by the manufacturer.

Operator variables

Ambient conditions in the operating theatre have a strong impact on the final properties of a bone cement. The cements used in studies I–IV were chilled to 4°C prior to mixing and vacuum mixed at 23°C, conditions that imitate typical clinical use (Carlsson et al. 1993, Smeds et al. 1997).

It has been shown that prechilling of the cement lowers the viscosity (Lidgren et al. 1987) and increases the setting time (Pearson et al. 1975, Lewis 1999b). However, fatigue properties are not significantly influenced by temperature alone (Lidgren et al. 1987, Lewis 1999b) but when chilling is combined with vacuum mixing, fatigue life improves. Thus, chilling and vacuum mixing should be considered in combination; prechilling is a precondition for vacuum mixing by eliminating the risk of the monomer boiling (Lidgren et al. 1987, Wixson 1992) and it prolongs the cement's working time and maintains a lower viscosity, making it injectable. The porosity of a bone cement is claimed to be one of the most important factors in its mechanical behaviour during *in vivo* use (Jasty et al. 1991, Boss et al. 1994, Murphy and Prendergast 2002, Ries et al. 2006). It has been hypothesized that initial damage to the cement is caused by shrinkage stress due to polymerisation contraction (Gilbert et al. 2000, Orr et al. 2003, Race et al. 2005) causing voids and porosity in the cement, but voids can also occur through air entrapment during mixing, inclusion of fluids and monomer boiling (Kuehn et al. 2005a). Pores may act as sites of crack initiation and stress raisers but may also stop crack propagation (Topoleski et al. 1993). Porosity was not measured in this study and samples with macroscopic defects on the surface (big voids) were discarded. This may have introduced a selection bias towards better mechanical results.

Vacuum mixing has been proven to reduce porosity and improve the fatigue performance of bone cements (Lidgren et al. 1987, Linden 1989, Norman et al. 1995, Lewis 1999b) as well as increasing their strength (Lidgren et al. 1984, Alkire et al. 1987, Lewis et al. 1998). The low viscosity bone cements are exceptions and seem not to be improved by vacuum mixing (Hansen and Jensen 1992, Lewis et al. 1998). The mixing system itself influences the cement properties. Hence, in all our studies, the system that had resulted in the best mechanical properties was used (Wang et al. 1996, Dunne and Orr 2001, Mau et al. 2004).

Langdown et al. have demonstrated that ambient theatre temperatures influence the mechanical properties of cements (Langdown et al. 2006). Cement setting time was reduced by higher temperatures. Even more important was the finding that setting time varied widely within a given temperature range. This could have a crucial impact on the success of an arthroplasty: cement mechanical properties, together with the sur-

face preparation of the implant (Howell et al. 2004, Perez et al. 2006, Smailys et al. 2007), are known to influence the longevity of arthroplasties (Gruen et al. 1979). Cements are technique-sensitive materials and require standardized handling in order to produce reproducible results (Lewis and Austin 1994, Lewis et al. 2005a). We took these factors into consideration and performed our mixing, aging and testing as closely as possible to actual clinical conditions.

Clinically, the mixing result is often characterised by a high degree of variability despite a mostly standardized procedure (Dunne et al. 2005). Thus, it is somewhat surprising that the overall results of cemented THAs are good; a *post mortem* study of the cement mantle in THAs has shown that about 80% of analysed stems have some defects (Janssen 2008, Bishop et al. 2009). While the cement mantle may be partly inadequate, these implants maintained good function, suggesting either that the patient adapts to a lower activity level or the material forgives these quality failures. On the other hand, this is consistent with the theory that wear debris is the most important cause of aseptic implant loosening (Jasty et al. 1986, Hirakawa et al. 2004, Bader et al. 2005).

Blood entrapment has been shown to weaken cement properties (Bannister et al. 1990, Majkowski et al. 1994, Gravius et al. 2007) but this effect was not studied in our experiments under optimal laboratory conditions.

Test procedures

Bone cements have been evaluated mechanically using different test methods and under different conditions (Harper and Bonfield 2000, Lewis and Nyman 2000, Lewis 2003).

Testing in compression, as in Studies I–IV, is considered clinically relevant (Huiskes and Verdonshot 1997). The compressive strength of bone cements is higher than that obtained from testing in bending or tension (Kuehn et al. 2005b). Moreover, in the relevant standards (American Society for Testing and Materials 1999, ISO 2002), compression testing is seen as the preferred method.

Advanced preclinical *in vitro* testing in the form of fatigue testing has been described (Lewis 2003) as a method for assessing the long term survival of bone cements but there are still many areas of disagreement, so there is a need to standardize methods and conditions for these tests.

Creep testing under dynamic loads simulates more closely the clinical situation than does conventional static testing. The cyclically loaded specimens are allowed to recover once in every loading cycle, leading to less creep compared with statically loaded specimens (Chwirut 1984). By walking, a patient subjects a well-functioning THA about 2 million cycles per year on average (Silva et al. 2002, Breusch and Kuhn 2003), so the 600,000 test cycles in Study IV represent a rather short time. The test frequency of 1 Hz mimics loading during normal gait (Morlock et al. 2001) but the test conditions in our study do not include the effects of rest periods.

Retrievals (Study IV)

The National Institutes of Health stated that “implant retrieval and analysis may provide the best opportunity to understand the long-term consequences of implantation and provide input to the evolutionary development of future implant technology.” (National Institutes of Health 2000). This highlights the importance of implant retrieval studies, which have opened up important insights into failure mechanisms of arthroplasties (Hirakawa et al. 2004).

However, access to bone cement specimens for mechanical testing is often limited as the cement frequently fragments during its removal from the femoral medullary cavity. The degree of stress to which the cements were exposed and the *in vivo* localization of the cement fragment is often unknown, as was the case in Study IV. Furthermore, the retrieved bone cement specimens came from arthroplasties that had been revised because of loosening for different reasons. In particular, Boneloc cement was often fragmented and disintegrated easily (Riegels-Nielsen et al. 1995), indicating a major cement damage which could cause inferior quasistatic and creep properties. These results should therefore be interpreted on a qualitative basis.

Additionally, the retrieved specimens were subjected to selection. Specimens with macroscopic defects were discarded, leading to selection bias, as only the macroscopically intact specimens were used for testing.

Storage medium and water uptake

Multiphasic PMMA-based polymers absorb some water on storage (Schmitt et al. 2004). The increase in mass, interpreted as due to water uptake, of the specimens stored in water (Studies I–IV) and plasma (Study II) of about 1.8% is in line with expectations in the standard for dental acrylic resins, which are comparable with bone cements (ISO 1999). Other authors have also reported water uptake of around 2% in polymeric materials (Örtengren et al. 2001, Schmitt et al. 2004, Kuehn et al. 2005b)

The water uptake in polymers is a diffusion controlled process (Deb et al. 1995). Two mechanisms for this process are discussed in the literature. One is the “Free volumetric theory” in which water diffuses through micro-voids without any relationship to the polar molecules in the material. The other is that water sorption characteristics are governed by specific molecular interactions (Bellenger and Verdu 1989) where water diffuses through the material by binding to the hydrophilic bonds. This theory is favoured by Unemori et al. and Bellenger et al. (Bellenger and Verdu 1989, Unemori et al. 2003) while Akashi et al. (Akashi et al. 1999) tends to the free volumetric theory. However, any water uptake at all is important for the mechanical and chemical properties of PMMA-based bone cements and, in this context, the mechanism is of subordinate importance.

Lipid solutions have been claimed to be preferable as a storage medium because of the very fatty conditions in the bone marrow. There was supposed to be better liquid diffusion into the cement, or easier leaching of low molecular mass species out of the cement, due to the hydrophobic nature of methyl methacrylate (Hailey et al. 1994, Lee et al. 2002). Even if the differences in mechanical properties compared with storing in water were small, one study demonstrated an increased creep rate and a lower energy needed for fracturing (work of fracture – WOF) when specimens had been stored in a lipid-containing solution as compared with storage in water (Hailey et al. 1994). Physiological salts have no effect on the post-curing chemical changes in bone cements (Hailey et al. 1994). However, the composition of the storing fluid is of minor importance as we have shown in Study II. Storage in plasma and storage in water gave approximately identical test values.

It has been shown that the elastic modulus of homogeneous cast PMMA is lowered when exposed to humidity (Ishiyama and Higo 2002). After approximately 3 months, the cement seems to be saturated with water (Studies I–III) (Schmitt et al. 2004, Kuehn et al. 2005b) as there are only smaller changes in properties thereafter. Water acts as a plasticizer, but also as a crazing initiator (Øysæd and Ruyter 1987, Akashi et al. 1999). The plasticizing effect of water (Ruyter and Svendsen 1980, Deb et al. 1995, Akashi et al. 1999, Unemori et al. 2003, Schmitt et al. 2004) is the dominant factor when testing acrylic bone cements, as we have shown in Study III. All competing changes in the cement are overshadowed by this effect.

Optical findings

The optical microstructural differences between specimens tested after short and long term storage revealed different patterns of mechanical failure. It appears that the bond between the pre-polymer beads and the polymer formed *in situ* is more coherent in the later stages of cement life, probably due to a stronger molecular semi-interpenetrating network (semi-IPN) (Puska et al. 2004). It has been shown earlier that crazes are formed at the interface between the matrix and polymer beads in auto-polymerised PMMA-based materials (Øysæd and Ruyter 1987).

Quasistatic properties

We have shown, in Studies I–III, that the mechanical properties of self-curing bone cement change during a storage period of five years. The evolution of mechanical properties of a bone cement differed between storage in air and storage in water, whereas there were no differences between storage in water and in plasma (Study II). Moreover, we found that testing in accordance with the specifications (air 23°C) always gave

higher values than storage and testing under more physiological conditions (water 37°C).

The evolution of the mechanical properties of a cement can be considered to be the result of different processes going on simultaneously in the material. Firstly, the increase in strength and modulus observed within the first week can be looked on as a result of rapid polymerisation by the free radical polymerisation process, which implies an increase in molecular weight (Basker et al. 1989) and the onset of physical aging (Struik 1978, Cizmecioglu et al. 1981, Hay 1995). Aging is a basic feature of the glassy state of PMMA and of all other polymer glasses. It is defined as a process that occurs in a polymeric material during a specified period of time, and it usually results in changes in physical structure (Hatada et al. 1996, Hughes et al. 2003). Incomplete curing results in a residual monomer content of about 2% - 6% (Hailey et al. 1994, Algers et al. 2003, Vallo et al. 2004, Kühn 2005, Kuehn et al. 2005a), decreasing within the following three weeks to approximately 0.5% (Kühn 2000). Residual monomer has a plasticizing effect and influences the mechanical and thermal properties of bone cement by reducing its mechanical strength, glass transition temperature (T_g), and thermal stability. Incomplete curing and increased monomer content, which decreases within three weeks, increases impact strength (Hailey et al. 1994, Algers et al. 2003, Vallo et al. 2004). This effect influenced our early test results, especially in Studies I and II. We cannot quantify this effect, as the residual monomer content was not measured.

Secondly, water uptake has a plasticizing effect (Ruyter and Svendsen 1980, Schmitt et al. 2004) which leads to weakening of the cement (Deb et al. 1995, Akashi et al. 1999, Unemori et al. 2003, Kjellson et al. 2004).

The effects of the polymerisation process dominate in the first week, whereas the plasticizing effect of water dominates thereafter, resulting in lowering of strength and modulus. On the other hand, increase in maximum strain might have an effect by lowering the brittleness, and it possibly affects the fatigue properties of the cement. The maximum strain is interpreted as an indicator of strain at failure and thus serves as a measure of the ductility (plastic deformability) of the cement. This value increases continuously over the first year, a finding that also can be explained by the effect of water uptake. The distinct differences in the evolution of mechanical properties between specimens stored and tested under wet vs. dry conditions reveal this effect.

Taking into account the results of Study III, the plasticizing effect of water is reversible, while the effect of physical aging continues even in the presence of water.

It is noteworthy that, after 20 minutes, the strength of Palacos cum Gentamicin is only 66% and its elastic modulus only 78% of the peak values for the material. Together with the low maximum strain values, this reveals that the cement is fragile at this early stage yet clinically it could be subjected to heavy forces, *e.g.* by joint reduction during arthroplasty, usually performed after 10–15 minutes. At this time, microcracks

could be produced, which could increase the risk of fatigue fractures in the cement mantle (Langdown et al. 2006), and possibly influence the long term clinical outcomes (Jasty et al. 1991). This assumption is consistent with a reported high rate of aseptic loosening in cemented implants with operating times lower than 51 minutes (Småbrekke et al. 2004), suggesting that the cement may have been loaded at a very early stage. This assumption is further supported by our optical findings, which showed poor coherence between the prepolymer beads and the matrix in the early stage after mixing.

The effect of temperature in the range between 23°C and 37°C on a bone cement in air seems to be less important (Baleani et al. 2001), as judged by a comparison of the results of Studies I and II and as mentioned by Ogawa et al. (Ogawa and Hasegawa 2005). Recalling that T_g for Palacos R after 4 weeks storage in dry 37°C air is 86°C, and after storage in 37°C water it is 67°C (Kühn 2000), the effect of a 14°C difference in testing temperature could be ignored in air as the cement is in the glassy state, far from T_g , but such an effect could be enhanced in the presence of water (Hailey et al. 1994, Arnold and Venditti 2001) as T_g is not far from the testing temperature and the cement becomes more rubbery (Breusch and Kuhn 2003). This effect is even more important for the Boneloc cement, which has a T_g of only 79°C (Thanner et al. 1995) in 23°C air; this could explain the results from Study IV.

Creep properties

Creep is defined as time-dependent increase in strain in a material under constant or cyclic stress (Chao and Aro 1997). Creep is a very sensitive variable. It is influenced by the chemical composition and micro-structural properties as well as operator controlled variables like vacuum mixing or injection time.

It has been shown that creep strain of PMMA increases with delayed injection time (Norman et al. 1997), stress level (Chwirut 1984, Norman et al. 1995, Verdonschot and Huiskes 1995), temperature (Ruyter and Espevik 1980, Chwirut 1984) and water sorption (Kildal and Ruyter 1997) and decreases with vacuum mixing (Norman et al. 1995). Frequency has not been shown to influence creep behaviour (Lewis et al. 2003) but differences in chemical composition like molecular weight (Liu et al. 2002) and additives like radioopacifier are known to affect creep (Verdonschot and Huiskes 2000, Harper and Bonfield 2000, Liu et al. 2002).

The strain recorded during cyclic creep testing in Study IV includes the elastic strain that is about 2% at 50 MPa at an elastic modulus of about 2.5 GPa. The accelerating deformation recorded towards the end of testing in Study IV indicated an effect of damage accumulation (Jeffers et al. 2005).

Creep is very sensitive to the ambient temperature (Liu et al. 2002, Liu et al. 2005). Thus, implant heating under stress (Bergmann et al. 2007) could lead to higher creep rates than

those measured in our study. Additionally, we measured creep under optimal uni-directional loading conditions *in vitro* and have not taken account of elements affecting creep in the *in vivo* situation; these could include multidirectional loading patterns, cement mantle thickness, porosity, prosthetic shape, prosthetic surface, prosthesis-cement and the cement-bone interface.

Bone cement creeps faster under tension than under compression (Verdonschot and Huiskes 1995) but compressive loading of the cement is most likely to be the dominant mode of loading of the cement mantle (Huiskes and Verdonschot 1997).

Creep may be a property that is not just detrimental. Some creep may be beneficial, as it allows adaptation between the stem and the cement (Verdonschot and Huiskes 1997, Huiskes et al. 1998, Norman et al. 2001). The somewhat better outcome of Boneloc cement with the Exeter prosthesis is consistent with this (Furnes et al. 1997, Thomsen et al. 2000, Bader et al. 2005).

Our finding that the medium viscosity cement CMW3G showed less creep than the high viscosity type (Palacos) could be explained by slight differences in chemical composition. It had been shown earlier that Palacos R-40 cement creeps more than CMW1 cement (Liu et al. 2002), suggesting that Palacos is more “ductile” and able to absorb impact energy better.

The cement with the anticipated best clinical performance showed a higher creep rate, compared with the medium viscosity cement. This observation suggests that some creep may be advantageous. Excessively high creep rates, as observed in the Boneloc cement, are detrimental with respect to clinical behaviour.

Creep could be an important input parameter for simulating stress distribution, damage development and cement mantle life time (Kuzmychov et al. 2009). However, it was shown that physical aging has a significant influence on the creep compliance and therefore creep tests should be performed at different aging times in order to demonstrate the short term and long term effects of aging (Kuzmychov et al. 2009).

Conclusions

- The strength of bone cements develops more slowly than the apparently high initial setting rate indicates.
- There are changes in the mechanical properties of bone cements over a time frame of five years.
- Testing bone cements as recommended by the ISO and ASTM specifications always resulted in higher values than testing at simulated physiological conditions. There is a need for more clinically relevant test methods and associated conditions in test standards. Testing of bone cements should be performed after extended aging under simulated physiological conditions.
- The effect of water absorption on bone cements on the physical properties is important but the mechanical changes caused by physical aging remain after immersion in water.
- Simple quasistatic and dynamic creep tests seem unable to predict the clinical performance of an acrylic bone cement when the products are chemically very similar. However, such testing may be clinically relevant for cements which exhibit substantial differences

Future research

The increasing demand for joint replacement surgery will lead to the appearance of new bone cement products on the market and the release of reformulations of established bone cement brands by the manufacturers. It is therefore of importance that orthopaedic surgeons know the properties of these products before taking them in use. Generally, cementless fixation of joint prostheses has hitherto not been consistently superior to cemented fixation and one might expect continued use of bone cements. Further research on bone cements is therefore warranted. New products and reformulations of established brands will require study. The properties of new products should be critically evaluated by independent research laboratories to avoid bias by commercial interests.

Since clinical data are always necessary for the final evaluation of any new product, laboratory studies should be linked to registries of implant survival. Cement samples could be systematically collected intraoperatively when performing a replacement THA and the samples linked to each patient's data in the register of implant survival. Mechanical *in vitro* tests could be performed on these cement samples and combined with register data. In revisions, retrieved bone cement should be collected and examined. A centralised database for retrieved joint prostheses should be established; this could contribute new knowledge on cement problems as well as other factors in prosthesis failure.

This work demonstrated that too high and too low creep properties of a bone cement are associated with clinically inferior results. While some creep seems to be beneficial, too much creep appears to be disadvantageous. Defining an upper and lower creep limit for new bone cement formulations under relevant conditions should be a goal of new research efforts and could become part of standard requirements. Consideration should be given to defining an upper limit for the quasi-static properties.

Subjecting cement samples to dynamic load testing, followed by quasistatic testing, may mimic the clinical condi-

tions more closely and should be compared with results from retrievals.

Further research is needed on the technique sensitivity of acrylic bone cements. While researchers are able to reproduce good and consistent results under optimised laboratory conditions, the clinical workday is affected by stresses, urgencies and lack of time and routine procedural mistakes, such as mixing cement wrongly, are not uncommon. As Dunne et al. (Dunne et al. 2005) reported, cement mixing procedures can give highly variable results even when well trained staff perform the mixing. It would be possible to collect cement samples in the operating theatre, and to note ambient conditions (temperature, relative humidity), with a view to establishing a quality control of the procedure.

Viscosity characteristics and the effect of manipulation during cement setting should be examined. Optical analyses could possibly reveal differences between cements at different points in time and after manipulations mimicking the procedures in the operating theatre.

Another avenue for improving the results of a THA would be better coherence between bone, cement and prosthesis. On the one hand, to improve bone–cement coherence, the formulation could be changed to reduce inflammatory reactions that may lead to aseptic loosening. Radioopacifiers like BaSO₄ and ZrO₂ could be changed (O'Brien et al. 2009). On the other hand, cement–prosthesis coherence could be improved by modifying the surface of the implant, possibly by making the surface characteristics of the materials more similar, perhaps by monomer coating the stem or wetting a porous stem with monomer fluid.

Nevertheless, it is not easy to improve a material that is already associated with such good results as present-day THAs. Over 90% survive more than 15 years, implying that most patients treated with a THA will keep their first prosthesis for the rest of their days.

Acknowledgements

This study was undertaken at the Department of Orthopaedic Surgery, Haukeland University Hospital, Bergen, Norway.

Firstly, I would like to express my gratitude to my supervisors *Professor emeritus Dr. med. Anders Odd Mølster* and *Professor Dr. odont. Nils Roar Gjerdet*. They made this thesis possible. *Anders* was my first supervisor in orthopaedic surgery, recruited me early to the Orthopaedic Biomaterials laboratory and introduced me to *Nils Roar* and the field of materials science. *Nils Roars'* profound knowledge, dedication to scientific work, kindness and helpfulness as well as *Anders'* enthusiasm and visions motivated me to complete this thesis. I am grateful for the guidance, teaching and constructive discussions through this long and difficult work. I am proud to have been their student.

I am also grateful to my research technician *Irene Ohlen Moldestad* for her help, tireless work and outstanding fatigue duty. She always has a smile and is in good spirits. This thesis would not have been possible without your help.

I owe *Dr. med. Wilhelm Schmidt* a great dept of gratitude for introducing me to scientific work when I was a young medical student and for teaching me that research is the essence of medical science. His wife, *Claudia*, deserves a special thanks for her patience when we were writing our papers at night, as do my godson *Christoph* and his brother *Paul*. You are all great friends.

A special thanks also to *Dr. med. Sven Byström*, former head of the department, as well as his successor *Professor Dr. med. Leif Ivar Havelin* and the current head of the department and my co-author, *Professor Dr. med. Ove Furnes*, for giving me the opportunity to work at the Department of Orthopaedic Surgery and I wish to express my gratitude to the department for the support granted to my studies.

I would like to thank *all my colleagues at the Department of Orthopaedic Surgery, Haukeland University Hospital*, for making this workplace special, exciting, and lively with a friendly and convivial atmosphere.

Many thanks are also due to *Dr. med. Clement Trovik* for introducing me to orthopaedic tumour surgery and for teaching me operative skills. He deserves great credit for accommodating my research and supporting my efforts to complete this work.

Thanks also to the *staff of the Dental Biomaterials Adverse Reaction Unit*, Unifob Helse, especially *Odd Johann Lundberg*, for help in performing creep testing, *Zouhir Ekeland Allouni* for some drawings and *Paul Johann Høl* for helpful discussions.

I would like to thank my co-authors *Professor Dr. philos. Stein Atle Lie*, who assisted greatly with the statistical analyses, *Dr. rer. nat., Dr. philos. I. Eystein Ruyter* and *Professor Dr. William R. Walsh* for inspirational discussions and *Dr. med. Otto Schnell Husby* for providing data and support.

Anne Lise Salbu, the coordinator of the Centre for Bone- and Soft tissue Tumours, deserves a special thanks for her help with literature searches and unstinting support in work day life.

I acknowledge the financial support of *Sophies Minde Foundation*, the *Institute for Surgical Sciences, University of Bergen*, the *health authorities of Western Norway (Helse Vest RHF, Helse Bergen HF, Innovest AS)* and the *Charnley Award 2008 from OrtoMedic*.

The *Department of Laboratory Medicine* at Haukeland University Hospital deserves credit for providing plasma for this study.

Many others have been of great help and inspiration during this part of my life, especially my friends and relatives. You are not forgotten, although not mentioned.

Finally, I would like to express my sincere thanks and deep gratitude to my family for supporting and encouraging me throughout my life. My brother *Martin* and my sister *Petra* deserve big hugs.

This thesis is dedicated to my parents *Marika* and *Peter Notrott* for their love. They have always encouraged me to work harder, never to give up and to perform better.

References

- Akashi A, Matsuya Y, Unemori M, Akamine A. The relationship between water absorption characteristics and the mechanical strength of resin-modified glass-ionomer cements in long-term water storage. *Biomaterials* 1999; 20 (17): 1573-8.
- Algers J, Maurer F H, Eldrup M, Wang J S. Free volume and mechanical properties of Palacos(R) R bone cement. *J Mater Sci Mater Med* 2003; 14 (11): 955-60.
- Alkire M J, Dabezies E J, Hastings P R. High vacuum as a method of reducing porosity of polymethylmethacrylate. *Orthopedics* 1987; 10 (11): 1533-9.
- American Society for Testing and Materials. Standard specification for acrylic bone cement (ASTM F451-99a). 1999.
- Arnold J C, Venditti N P. Effects of environment on the creep properties of a poly(ethylmethacrylate) based bone cement. *J Mater Sci Mater Med* 2001; 12 (8): 707-17.
- Bader R, Mittelmeier W, Steinhauser E, Brehm P, Brem R, Tübel J, Choungthong P, Winklmaier D, Schmitt M, Holzwarth U. Abriebverhalten von zementierten Hüftendoprothesen-Stielen, Einfluss der Knochenzement-Zusammensetzung. *MP Materials Testing* 2005; 47 (4): 175-80.
- Baleani M, Cristofolini L, Toni A. Temperature and ageing condition effects on the characterization of acrylic bone cement. *Proc Inst Mech Eng [H]* 2001; 215 (1): 113-8.
- Bannister G C, Young S K, Baker A S, Mackinnon J G, Magnusson P A. Control of bleeding in cemented arthroplasty. *J Bone Joint Surg Br* 1990; 72 (3): 444-6.
- Basker R, Collier J, Smith I, Bratle K, Frere B, Wonng L. Variation of residual monomer content of poly(methyl methacrylate) dental resins with time, and the influence of water immersion. *Clin Mater* 1989; 4 (2): 173-82.
- Bellenger V, Verdu J. Structure-properties relationships for densely cross-linked epoxide-amine systems based on epoxide or amine mixtures. Part 2 Water absorption and diffusion. *J Mater Sci* 1989; 24 63-8.
- Bergmann G, Graichen F, Rohlmann A, Westerhoff P, Bender A, Gabel U, Heinlein B. Die Belastung orthopädischer Implantate. Messungen und praktische Anwendungen. [Loads acting on orthopaedic implants. Measurements and practical applications]. *Orthopade* 2007; 36 (3): 195-204.
- Bishop N E, Schoenwald M, Schultz P, Puschel K, Morlock M M. The condition of the cement mantle in femoral hip prosthesis implantations-a post mortem retrieval study. *Hip Int* 2009; 19 (2): 87-95.
- Boss J H, Shajrawi I, Mendes D G. The nature of the bone-implant interface. The lessons learned from implant retrieval and analysis in man and experimental animal. *Med Prog Technol* 1994; 20 (3-4): 119-42.
- Br Med J. DR. Smith-Petersen at Royal Society of Medicine. *Br Med J* 1952; 2 (4774): 39.
- Breusch S J, Kuhn K D. Knochenzemente auf Basis von Polymethylmethacrylat. [Bone cements based on polymethylmethacrylate]. *Orthopade* 2003; 32 (1): 41-50.
- Brock H S, Moodie P G, Hendricks K J, McIlff T E. Compression Strength and Porosity of Single-Antibiotic Cement Vacuum-Mixed With Vancomycin. *J Arthroplasty* 2009; in press.
- Brown S R, Davies W A, DeHeer D H, Swanson A B. Long-term survival of McKee-Farrar total hip prostheses. *Clin Orthop Relat Res* 2002; (402): 157-63.
- Carlsson A S, Nilsson J A, Blomgren G, Josefsson G, Lindberg L T, Onnerfalt R. Low- vs high-viscosity cement in hip arthroplasty. No radiographic difference in 226 arthrosis cases followed for 5 years. *Acta Orthop Scand* 1993; 64 (3): 257-62.
- Carlsson Å S. Comparison of Different Bone Cements: An Overview. In: *Biomaterials in Surgery* (Ed. Walenkamp G H I M). Georg Thieme Verlag, Stuttgart, New York 1998; 43-7.
- Chao E Y S, Aro H T. Biomechanics of Fracture Fixation. In: *Basic Orthopaedic Biomechanics* (Ed. Mow V C and Hayes W C). Lippincott-Raven Publishers. Philadelphia 1997; 2: 317-51.
- Charnley J. Arthroplasty of the hip. A new operation. *Lancet* 1961; 1 (7187): 1129-32.
- Charnley J. Surgery of the hip-joint: present and future developments. *Br Med J* 1960; 1 (5176): 821-6.
- Chwirut D J. Long-term compressive creep deformation and damage in acrylic bone cements. *J Biomed Mater Res* 1984; 18 (1): 25-37.
- Cizmecioglu M, Fedors R, Hong S, Moacanin J. Effect of physical aging on stress relaxation of poly(methyl methacrylate). *Polymer Engineering and Science* 1981; 21 (14): 940-2.
- Davies J P, Jasty M, O'Connor D O, Burke D W, Harrigan T P, Harris W H. The effect of centrifuging bone cement. *J Bone Joint Surg Br* 1989a; 71 (1): 39-42.
- Davies J P, O'Connor D O, Burke D W, Harris W H. Influence of antibiotic impregnation on the fatigue life of Simplex P and Palacos R acrylic bone cements, with and without centrifugation. *J Biomed Mater Res* 1989b; 23 (4): 379-97.
- Deb S, Braden M, Bonfield W. Water absorption characteristics of modified hydroxyapatite bone cements. *Biomaterials* 1995; 16 (14): 1095-100.
- Demian H W, McDermott K. Regulatory perspective on characterization and testing of orthopedic bone cements. *Biomaterials* 1998; 19 1607-18.
- Dunbar M J. Antibiotic bone cements: their use in routine primary total joint arthroplasty is justified. *Orthopedics* 2009; 32 (9): in press.
- Dunne N, Daly C, Beverland D, Nixon J, Wilson R, Carey G, Orr J. Third generation bone cement mixing systems, are they doing the job? *J Bone Joint Surg Br* 2005; 87-B (SUPP III): 262-3.
- Dunne N J, Orr J F. Influence of mixing techniques on the physical properties of acrylic bone cement. *Biomaterials* 2001; 22 (13): 1819-26.
- Ege W, Kühn K-D, Tuchscherer C, Maurer H. Physical and Chemical Properties of Bone Cements. In: *Biomaterials in Surgery* (Ed. Walenkamp G H I M). Georg Thieme Verlag, Stuttgart, New York 1998; 39-42.
- Espehaug B, Fumes O, Havelin L I, Engesaeter L B, Vollset S E. The type of cement and failure of total hip replacements. *J Bone Joint Surg Br* 2002; 84 (6): 832-8.
- Furnes O, Havelin L I, Espehaug B, Steindal K, Sørås T E. The Norwegian Arthroplasty Register, REPORT 2008. Helse-Bergen HF, Department of Orthopaedic Surgery, Haukeland University Hospital, <http://www.haukeland.no/nrl/>, Bergen, Norway 2008.
- Furnes O, Lie S A, Havelin L I, Vollset S E, Engesaeter L B. Exeter and Charnley arthroplasties with Boneloc or high viscosity cement. Comparison of 1,127 arthroplasties followed for 5 years in the Norwegian Arthroplasty Register. *Acta Orthop Scand* 1997; 68 (6): 515-20.
- Gilbert J L, Hasenwinkel J M, Wixson R L, Lautenschlager E P. A theoretical and experimental analysis of polymerization shrinkage of bone cement: A potential major source of porosity. *J Biomed Mater Res* 2000; 52 (1): 210-8.
- Gluck T. Die Invaginationsmethode der Osteo- und Arthroplastik. *Berliner Klinische Wochenschrift* 1890; 32 732-6.
- Gluck T. Referat über die durch das moderne chirurgische Experiment gewonnenen positiven Resultate, betreffend die Naht und den Ersatz von Defekten höherer Gewebe, sowie über die Verwerthung resorbierbarer und lebendiger Tampons in der Chirurgie. *Langenbecks Archiv für klinische Chirurgie* 1891; 41 187-239.
- Gravius S, Wirtz D C, Marx R, Maus U, Andereya S, Muller-Rath R, Mumme T. Mechanische In-vitro-Prüfung von funfzehn kommerziellen Knochenzementen auf der Basis von Polymethylmethacrylat. [Mechanical in vitro testing of fifteen commercial bone cements based on polymethylmethacrylate]. *Z Orthop Unfall* 2007; 145 (5): 579-85.

- Grossman J, Mackenzie F J. The randomized controlled trial: gold standard, or merely standard? *Perspect Biol Med* 2005; 48 (4): 516-34.
- Gruen T A, McNeice G M, Amstutz H C. „Modes of failure“ of cemented stem-type femoral components: a radiographic analysis of loosening. *Clin Orthop Relat Res* 1979; (141): 17-27.
- Hailey J L, Turner I G, Miles A W, Price G. The effect of post-curing chemical changes on the mechanical properties of acrylic bone cement. *J Mater Sci Mater Med* 1994; 5 (9-10): 617 - 21.
- Hallab N J, Jacobs J J, Katz J L. Orthopedic Applications. In: *Biomaterials Science: An Introduction to Materials in Medicine* (Ed. Ratner B D, Hoffman A S, Schoen F J and Lemons J E). Elsevier Academic Press. San Diego 2004; 2: 526-55.
- Hansen D, Jensen J S. Mixing does not improve mechanical properties of all bone cements. Manual and centrifugation-vacuum mixing compared for 10 cement brands. *Acta Orthop Scand* 1992; 63 (1): 13-8.
- Harper E J, Bonfield W. Tensile characteristics of ten commercial acrylic bone cements. *J Biomed Mater Res* 2000; 53 (5): 605-16.
- Harper E J, Braden M, Bonfield W, Dingeldein E, Wahlig H. Influence of sterilization upon a range of properties of experimental bone cements. *J Mater Sci Mater Med* 1997; 8 (12): 849-53.
- Hatada K, Fox R B, Kahovec J, Maréchal E, Mita I, Shibaev V. Definitions of terms relating to degradation, aging, and related chemical transformations of polymers (IUPAC Recommendations 1996). *Pure & Appl. Chem* 1996; 68 (12): 2313-23.
- Havelin L I, Espehaug B, Vollset S E, Engesaeter L B. The effect of the type of cement on early revision of charnley total hip prostheses - a review of 8,579 primary arthroplasties from the norwegian arthroplasty register. *J Bone Joint Surg* 1995; 77 (10): 1543-50.
- Havelin L I, Espehaug B, Vollset S E, Engesaeter L B, Langeland N. The Norwegian arthroplasty register. A survey of 17,444 hip replacements 1987-1990. *Acta Orthop Scand* 1993; 64 (3): 245-51.
- Hay J N. The physical ageing of amorphous and crystalline polymers. *Pure & Appl. Chem* 1995; 67 (11): 1855-8.
- Healy W L, Iorio R. Implant selection and cost for total joint arthroplasty: conflict between surgeons and hospitals. *Clin Orthop Relat Res* 2007; 457 57-63.
- Heck D, Rosenberg A, Schink-Ascani M, Garbus S, Kiewitt T. Use of antibiotic-impregnated cement during hip and knee arthroplasty in the United States. *J Arthroplasty* 1995; 10 (4): 470-5.
- Henrichsen E, Jansen K, Krough-Poulsen W. Experimental investigation of the tissue reaction to acrylic plastics. *Acta Orthop Scand* 1952; 22 (2): 141-6.
- Herberts P, Malchau H. Long-term registration has improved the quality of hip replacement: a review of the Swedish THR Register comparing 160,000 cases. *Acta Orthop Scand* 2000; 71 (2): 111-21.
- Hirakawa K, Jacobs J J, Urban R, Saito T. Mechanisms of failure of total hip replacements: lessons learned from retrieval studies. *Clin Orthop Relat Res* 2004; (420): 10-7.
- Howell J R, Jr., Blunt L A, Doyle C, Hooper R M, Lee A J, Ling R S. In vivo surface wear mechanisms of femoral components of cemented total hip arthroplasties: the influence of wear mechanism on clinical outcome. *J Arthroplasty* 2004; 19 (1): 88-101.
- Hughes K F, Ries M D, Pruitt L A. Structural degradation of acrylic bone cements due to in vivo and simulated aging. *J Biomed Mater Res* 2003; 65A (2): 126-35.
- Huiskes R, Verdonschot N. Biomechanics of Artificial Joints: The Hip. In: *Basic Orthopaedic Biomechanics* (Ed. Mow V C and Hayes W C). Lippincott-Raven Publishers. Philadelphia 1997; 2: 395-460.
- Huiskes R, Verdonschot N, Nivbrant B. Migration, stem shape, and surface finish in cemented total hip arthroplasty. *Clin Orthop Relat Res* 1998; (355): 103-12.
- Hulliger L. Untersuchungen über die Wirkung von Kunstharzen (Palacos und Ostamer) in Gewebekulturen. *Arch. orthop. Unfall-Chir.* 1962; 54 581.
- International Organization for Standardization. The ISO Story. 2008. http://www.iso.org/iso/about/the_iso_story.htm.
- Iorio R, Healy W L, Richards J A. Comparison of the hospital cost of primary and revision total hip arthroplasty after cost containment. *Orthopedics* 1999; 22 (2): 185-9.
- Ishiyama C, Higo Y. Effects of humidity on Young's modulus in poly(methyl methacrylate). *J Polym Sci Part B: Polymer Physics* 2002; 40 (5): 460-5.
- ISO. International standard ISO 1567 - Dentistry - Denture base polymers. International Organization for Standardization, Geneva 1999.
- ISO. International standard ISO 5833 Implants for surgery - Acrylic resin cements. International Organization for Standardization, Geneva 2002;
- Jacobsson S A, Djerf K, Wahlstrom O. Twenty-year results of McKee-Farrar versus Charnley prosthesis. *Clin Orthop Relat Res* 1996; (329 Suppl): S60-8.
- Janssen S. Es knirscht in der Hüfte. *DIE ZEIT* 24.04.2008; 18: 45.
- Jasty M, Davies J P, O'Connor D O, Burke D W, Harrigan T P, Harris W H. Porosity of various preparations of acrylic bone cements. *Clin Orthop* 1990; (259): 122-9.
- Jasty M, Jiranek W, Harris W H. Acrylic fragmentation in total hip replacements and its biological consequences. *Clin Orthop* 1992; (285 Dec): 116-28.
- Jasty M, Maloney W J, Bragdon C R, O'Connor D O, Haire T, Harris W H. The initiation of failure in cemented femoral components of hip arthroplasties. *J Bone Joint Surg Br* 1991; 73 (4): 551-8.
- Jasty M, Smith E. Wear particles of total joint replacements and their role in periprosthetic osteolysis. *Curr Opin Rheumatol* 1992; 4 (2): 204-9.
- Jasty M J, Floyd W E, 3rd, Schiller A L, Goldring S R, Harris W H. Localized osteolysis in stable, non-septic total hip replacement. *J Bone Joint Surg Am* 1986; 68 (6): 912-9.
- Jeffers J R, Browne M, Taylor M. Damage accumulation, fatigue and creep behaviour of vacuum mixed bone cement. *Biomaterials* 2005; 26 (27): 5532-41.
- Johnston R C. Acrylic bone cement: clinical development and current status in North America. *Orthop Clin North Am* 2005; 36 (1): 75-84.
- Judet J, Judet R. The use of an artificial femoral head for arthroplasty of the hip joint. *J Bone Joint Surg Br* 1950; 32-B (2): 166-73.
- Kildal K K, Ruyter I E. How different curing methods affect mechanical properties of composites for inlays when tested in dry and wet conditions. *Eur J Oral Sci* 1997; 105 (4): 353-61.
- Kjellson F, Brudeli B, McCarthy I D, Lidgren L. Water uptake and release from iodine-containing bone cement. *J Biomed Mater Res A* 2004; 71 (2): 292-8.
- Kleinschmidt O. Plexiglas zur Deckung von Schädelücken. *Chirurg* 1941; 13 273.
- Kuehn K-D, Ege W, Gopp U. Acrylic bone cements: composition and properties. *Orthop Clin North Am* 2005a; 36 (1): 17-28.
- Kuehn K-D, Ege W, Gopp U. Acrylic bone cements: mechanical and physical properties. *Orthop Clin North Am* 2005b; 36 (1): 29-39.
- Kurtz S M, Villarraga M L, Zhao K, Edidin A A. Static and fatigue mechanical behavior of bone cement with elevated barium sulfate content for treatment of vertebral compression fractures. *Biomaterials* 2005; 26 (17): 3699-712.
- Kuzmychov O, Koplín C, Jaeger R, Buchner H, Gopp U. Physical aging and the creep behavior of acrylic bone cements. *J Biomed Mater Res B Appl Biomater* 2009; in press.
- Kühn K-D. Bone cements. Up-to-date comparison of physical and mechanical properties of commercial materials. Springer Verlag, Heidelberg 2000.
- Kühn K-D. Properties of Bone Cement: What is Bone Cement? In: *The Well-Cemented Total Hip Arthroplasty - Theory and Practice* (Ed. Breusch S and Malchau H). Springer Medizin Verlag. Berlin Heidelberg New York 2005; 52-9.
- Kärrholm J, Garellick G, Herberts P. Swedish Hip Arthroplasty Register, Annual Report 2006. Department of Orthopaedics, Sahlgrenska University Hospital, www.jru.orthop.gu.se, Gothenburg, Sweden 2007;
- Langdown A J, Tsai N, Auld J, Walsh W R, Walker P, Bruce W J. The influence of ambient theater temperature on cement setting time. *J Arthroplasty* 2006; 21 (3): 381-4.

- Lee A J, Ling R S, Gheduzzi S, Simon J P, Renfro R J. Factors affecting the mechanical and viscoelastic properties of acrylic bone cement. *J Mater Sci Mater Med* 2002; 13 (8): 723-33.
- Lewis G. Apparent fracture toughness of acrylic bone cement: effect of test specimen configuration and sterilization method. *Biomaterials* 1999a; 20 (1): 69-78.
- Lewis G. Effect of mixing method and storage temperature of cement constituents on the fatigue and porosity of acrylic bone cement. *J Biomed Mater Res* 1999b; 48 (2): 143-9.
- Lewis G. Fatigue testing and performance of acrylic bone-cement materials: state-of-the-art review. *J Biomed Mater Res* 2003; 66B (1): 457-86.
- Lewis G. Relative roles of cement molecular weight and mixing method on the fatigue performance of acrylic bone cement: Simplex P versus Osteopal. *J Biomed Mater Res* 2000; 53 (1): 119-30.
- Lewis G, Austin G E. Mechanical properties of vacuum-mixed acrylic bone cement. *J Appl Biomater* 1994; 5 (4): 307-14.
- Lewis G, Janna S, Bhattaram A. Influence of the method of blending an antibiotic powder with an acrylic bone cement powder on physical, mechanical, and thermal properties of the cured cement. *Biomaterials* 2005a; 26 (20): 4317-25.
- Lewis G, Janna S, Carroll M. Effect of test frequency on the in vitro fatigue life of acrylic bone cement. *Biomaterials* 2003; 24 (6): 1111-7.
- Lewis G, Mladi S. Effect of sterilization method on properties of Palacos R acrylic bone cement. *Biomaterials* 1998; 19 (1-3): 117-24.
- Lewis G, Nyman J, Trieu H H. The apparent fracture toughness of acrylic bone cement: effect of three variables. *Biomaterials* 1998; 19 (10): 961-7.
- Lewis G, Nyman J S. Toward standardization of methods of determination of fracture properties of acrylic bone cement and statistical analysis of test results. *J Biomed Mater Res* 2000; 53 (6): 748-68.
- Lewis G, Nyman J S, Trieu H H. Effect of mixing method on selected properties of acrylic bone cement. *J Biomed Mater Res* 1997; 38 (3): 221-8.
- Lewis G, van Hooy-Corstjens C S, Bhattaram A, Koole L H. Influence of the radiopacifier in an acrylic bone cement on its mechanical, thermal, and physical properties: barium sulfate-containing cement versus iodine-containing cement. *J Biomed Mater Res B Appl Biomater* 2005b; 73 (1): 77-87.
- Lidgren L, Bodelind B, Moller J. Bone cement improved by vacuum mixing and chilling. *Acta Orthop Scand* 1987; 58 (1): 27-32.
- Lidgren L, Drar H, Moller J. Strength of polymethylmethacrylate increased by vacuum mixing. *Acta Orthop Scand* 1984; 55 (5): 536-41.
- Linden U. Fatigue properties of bone cement. Comparison of mixing techniques. *Acta Orthop Scand* 1989; 60 (4): 431-3.
- Liu C, Green S M, Watkins N D, Gregg P J, McCaskie A W. Creep behavior comparison of CMW1 and palacos R-40 clinical bone cements. *J Mater Sci Mater Med* 2002; 13 (11): 1021-8.
- Liu C Z, Green S M, Watkins N D, Baker D, McCaskie A W. Dynamic creep and mechanical characteristics of SmartSet GHV bone cement. *J Mater Sci Mater Med* 2005; 16 (2): 153-60.
- Majkowski R S, Bannister G C, Miles A W. The effect of bleeding on the cement-bone interface. An experimental study. *Clin Orthop Relat Res* 1994; (299): 293-7.
- Malchau H, Garellick G, Eisler T, Kärrholm J, Herberts P. Presidential guest address: the Swedish Hip Registry: increasing the sensitivity by patient outcome data. *Clin Orthop Relat Res* 2005; 441 19-29.
- Malchau H, Herberts P, Ahnfelt L. Prognosis of total hip replacement in Sweden. Follow-up of 92,675 operations performed 1978-1990. *Acta Orthop Scand* 1993; 64 (5): 497-506.
- Malchau H, Herberts P, Eisler T, Garellick G, Söderman P. The Swedish Total Hip Replacement Register. *J Bone Joint Surg Am* 2002; 84-A Suppl 2 2-20.
- Mau H, Schelling K, Heisel C, Wang J S, Breusch S J. Comparison of various vacuum mixing systems and bone cements as regards reliability, porosity and bending strength. *Acta Orthop Scand* 2004; 75 (2): 160-72.
- Metz C M, Freiberg A A. An international comparative study of total hip arthroplasty cost and practice patterns. *J Arthroplasty* 1998; 13 (3): 296-8.
- Morlock M, Schneider E, Bluhm A, Vollmer M, Bergmann G, Müller V, Honl M. Duration and frequency of every day activities in total hip patients. *J Biomech* 2001; 34 (7): 873-81.
- Mulroy W F, Estok D M, Harris W H. Total hip arthroplasty with use of so-called second-generation cementing techniques. A fifteen-year-average follow-up study. *J Bone Joint Surg Am* 1995; 77 (12): 1845-52.
- Murphy B P, Prendergast P J. The relationship between stress, porosity, and nonlinear damage accumulation in acrylic bone cement. *J Biomed Mater Res* 2002; 59 (4): 646-54.
- National Institutes of Health. Improving Medical Implant Performance Through Retrieval Information: Challenges and Opportunities. NIH Technology Assessment Conference Summary; January 10-12. 2000. <http://consensus.nih.gov/2000/2000MedicalImplantsta019html.htm>
- Nilsen A R, Wiig M. Total hip arthroplasty with Boneloc(R). Loosening in 102/157 cases after 0.5-3 years. *Acta Orthop Scand* 1996; 67 (1): 57-9.
- Norman T L, Kish V, Blaha J D, Gruen T A, Hustosky K. Creep characteristics of hand-mixed and vacuum-mixed acrylic bone-cement at elevated stress levels. *J Biomed Mater Res* 1995; 29 (4): 495-501.
- Norman T L, Thyagarajan G, Saligrama V C, Gruen T A, Blaha J D. Stem surface roughness alters creep induced subsidence and 'taper-lock' in a cemented femoral hip prosthesis. *J Biomech* 2001; 34 (10): 1325-33.
- Norman T L, Williams M, Gruen T A, Blaha J D. Influence of delayed injection time on the creep behavior of acrylic bone cement. *J Biomed Mater Res* 1997; 37 (2): 151-4.
- O'Brien D, Boyd D, Madigan S, Murphy S. Evaluation of a novel radiopacifying agent on the physical properties of surgical spineplex(R). *J Mater Sci Mater Med* 2009; in press.
- Oates K M, Barrera D L, Tucker W N, Chau C C M, Bugbee W D, Convery F R. In vivo effect of pressurization of polymethyl methacrylate bone-cement. Biomechanical and histologic analysis. *J Arthroplasty* 1995; 10 (3): 373-81.
- Ogawa T, Hasegawa A. Effect of curing environment on mechanical properties and polymerizing behaviour of methyl-methacrylate autopolymerizing resin. *J Oral Rehabil* 2005; 32 (3): 221-6.
- Orr J F, Dunne N J, Quinn J C. Shrinkage stresses in bone cement. *Biomaterials* 2003; 24 (17): 2933-40.
- Örtengren U, Wellendorf H, Karlsson S, Ruyter I E. Water sorption and solubility of dental composites and identification of monomers released in an aqueous environment. *J Oral Rehabil* 2001; 28 (12): 1106-15.
- Øysæd H, Ruyter I E. Formation and growth of crazes in multiphase acrylic systems. *J Mat Sci* 1987; 22: 3373-8.
- Pearson G P, Jones D F, Wright V. Letter: Effect of operating-theatre temperatures on the setting-times of acrylic cements for use in orthopaedic surgery. *Lancet* 1975; 2 (7926): 184.
- Perez M A, Garcia-Aznar J M, Doblare M, Seral B, Seral F. A comparative FEA of the debonding process in different concepts of cemented hip implants. *Med Eng Phys* 2006; 28 (6): 525-33.
- Puska M A, Narhi T O, Aho A J, Yli-Urpo A, Vallittu P K. Flexural properties of crosslinked and oligomer-modified glass-fibre reinforced acrylic bone cement. *J Mater Sci Mater Med* 2004; 15 (9): 1037-43.
- Race A, Miller M A, Clarke M T, Mann K A. Cement-implant interface gaps explain the poor results of CMW3 for femoral stem fixation: A cadaver study of migration, fatigue and mantle morphology. *Acta Orthop* 2005; 76 (5): 679-87.
- Ramsey S D, Luce B R, Deyo R, Franklin G. The limited state of technology assessment for medical devices: facing the issues. *Am J Manag Care* 1998; 4: SP188-99.
- Riegels-Nielsen P, Sørensen L, Andersen H M, Lindequist S. Boneloc cemented total hip prostheses. Loosening in 28/43 cases after 3-38 months. *Acta Orthop Scand* 1995; 66 (3): 215-7.
- Ries M D, Young E, Al-Marashi L, Goldstein P, Hetherington A, Petrie T, Pruitt L. In vivo behavior of acrylic bone cement in total hip arthroplasty. *Biomaterials* 2006; 27 (2): 256-61.
- Ruyter I E, Espevik S. Compressive creep of denture base polymers. *Acta Odontol Scand* 1980; 38 (3): 169-77.

- Ruyter I E, Svendsen S A. Flexural properties of denture base polymers. *J Prosthet Dent* 1980; 43 (1): 95-104.
- Saha S, Pal S. Mechanical properties of bone cement: a review. *J Biomed Mater Res* 1984; 18 (4): 435-62.
- Schmitt S, Krzypow D J, Rimmac C M. The effect of moisture absorption on the fatigue crack propagation resistance of acrylic bone cement. *Biomed. Technik* 2004; 49 (3): 61-5.
- Shardlow D L, Stone M H, Ingham E, Fisher J. Cement particles containing radio-opacifiers stimulate pro-osteolytic cytokine production from a human monocytic cell line. *J Bone Joint Surg Br* 2003; 85 (6): 900-5.
- Silva M, Shepherd E F, Jackson W O, Dorey F J, Schmalzried T P. Average patient walking activity approaches 2 million cycles per year: pedometers under-record walking activity. *J Arthroplasty* 2002; 17 (6): 693-7.
- Smailys A, Tarasevicius S, Kesteris U, Kalesinskas R J, Wingstrand H. Exeter total hip arthroplasty with matte or polished stems. *Medicina (Kaunas)* 2007; 43 (3): 215-20.
- Smeds S, Goertzen D, Ivarsson I. Influence of temperature and vacuum mixing on bone cement properties. *Clin Orthop Relat Res* 1997; (334): 326-34.
- Smith-Petersen M N. The classic: Evolution of mould arthroplasty of the hip joint by M. N. Smith-Petersen, *J. Bone Joint Surg.* 30B:L:59, 1948. *Clin Orthop Relat Res* 1978; (134): 5-11.
- Smith D C. The genesis and evolution of acrylic bone cement. *Orthop Clin North Am* 2005; 36 (1): 1-10.
- Småbrekke A, Espehaug B, Havelin L I, Furnes O. Operating time and survival of primary total hip replacements: an analysis of 31,745 primary cemented and uncemented total hip replacements from local hospitals reported to the Norwegian Arthroplasty Register 1987-2001. *Acta Orthop Scand* 2004; 75 (5): 524-32.
- Struik L C E. *Physical Aging In Amorphous Polymers And Other Materials.* Elsevier Scientific Publishing Company, Amsterdam 1978.
- Thanner J, Freij-Larsson C, Kärrholm J, Malchau H, Wesslen B. Evaluation of Boneloc. Chemical and mechanical properties, and a randomized clinical study of 30 total hip arthroplasties. *Acta Orthop Scand* 1995; 66 (3): 207-14.
- Thomsen P B, Bøvling S, Jacoby B, Hansen T B. Aseptic loosening of Boneloc cemented Exeter total hip replacement. A 5 year follow-up of the first 100 hips. *Hip Int* 2000; 10 102-7.
- Topoleski L D, Ducheyne P, Cuckler J M. Microstructural pathway of fracture in poly(methyl methacrylate) bone cement. *Biomaterials* 1993; 14 (15): 1165-72.
- Unemori M, Matsuya Y, Matsuya S, Akashi A, Akamine A. Water absorption of poly(methyl methacrylate) containing 4-methacryloxyethyl trimellitic anhydride. *Biomaterials* 2003; 24 (8): 1381-7.
- Vallo C I, Abraham G A, Cuadrado T R, San Roman J. Influence of cross-linked PMMA beads on the mechanical behavior of self-curing acrylic cements. *J Biomed Mater Res B Appl Biomater* 2004; 70 (2): 407-16.
- Venable C S, Stuck W G, Beach A. The Effects on bone of the presence of metals; Based upon electrolysis: An experimental study. *Ann Surg* 1937; 105 (6): 917-38.
- Verdonschot N, Huiskes R. Acrylic cement creeps but does not allow much subsidence of femoral stems. *J Bone Joint Surg* 1997; 79B (4): 665-9.
- Verdonschot N, Huiskes R. Creep properties of three low temperature-curing bone cements: A preclinical assessment. *J Biomed Mater Res* 2000; 53 (5): 498-504.
- Verdonschot N, Huiskes R. Dynamic creep-behavior of acrylic bone-cement. *J Biomed Mater Res* 1995; 29 (5): 575-81.
- Wang J S, Toksvig-Larsen S, Müller-Wille P, Franzèn H. Is there any difference between vacuum mixing systems in reducing bone cement porosity? *J Biomed Mater Res* 1996; 33 (2): 115-9.
- Watkins N D. The type of cement and failure of total hip replacements. *J Bone Joint Surg Br* 2003; 85 (5): 775-6.
- Wixson R L. Do we need to vacuum mix or centrifuge cement? *Clin Orthop* 1992; (285): 84-90.
- Yates P, Serjeant S, Rushforth G, Middleton R. The relative cost of cemented and uncemented total hip arthroplasties. *J Arthroplasty* 2006; 21 (1): 102-5.

